





















### Parts

| ITEM | PART # | QTY | DESCRIPTION                 |   | ITEM | PART # | QTY | DESCRIPTION                      |   |
|------|--------|-----|-----------------------------|---|------|--------|-----|----------------------------------|---|
| A    | 802    | 1   | Tub Track with Vinyl        |  | N    | VM-4   | 4   | Wall Channel Vinyl               |  |
| B    | 814    | 2   | Wall Jamb                   |  | O    | 150    | 1   | Bottom Guide                     |  |
| C    | 113    | 6   | Plastic Wall Anchor         |  | P    | 816    | 2   | Towel Bars                       |  |
| D    | 110    | 6   | #8 x 1 1/2" Pan Head Screw  |  | Q    | 119    | 4   | #6 x 1/2" Pan Head Screw         |  |
| E    | 841    | 1   | Tub Header 7700 Series      |  | R    | 117    | 2   | #10 x 7/8" Truss Head Screw      |  |
| F    | 824    | 1   | Tub Header 7500 Series      |  | S    | 118    | 2   | #10 x 1 1/8" Flat Head Screw     |  |
| G    |        | 1   | Glass Panel                 |  | T    | 158    | 4   | Towel Bar Trim Rings             |  |
| H    | 131    | 2   | Vinyl Jamb Bumpers          |  | U    | 138    | 4   | Acrylic Towel Bar Bracket        |  |
| I    | 115    | 2   | #6 x 3/4" Pan Head Screw    |  | V    | 136    | 2   | Acrylic Finger Pulls             |  |
| J    | 116    | 4   | #6 x 32-3/8" Hex Head Screw |  | W    | 137    | 2   | Cover Label                      |  |
| K    | 130    | 4   | Roller Bearing              |  | X    | 818    | 2   | 180-Degree Snap Post / Side Jamb |  |
| L    |        | 2   | Sliding Glass Door          |  | Y    | 148    | 1   | Glass Block                      |  |
| M    | 210    | 1   | Friction Sill               |  |      |        |     |                                  |   |

## Tools

---



Hacksaw



Philips Screwdriver



Level



3/16" and 1/8" Drill Bit



Drill



Tape Measure



Safety Glasses



Masking Tape

## Installation Notes

---

- Unpack your unit carefully. Lay out and identify all parts using the instruction sheets as a reference. Before discarding the carton, check for any small hardware bags.
- If any parts are damaged or missing, refer to the description noted in the instructions when contacting your dealer for replacements.
- Please wear safety glasses whenever drilling or cutting.
- Handle the glazed panels carefully; tempered glass is difficult to break, but the sharp corners of the panels can damage tile and floor coverings.
- Before installing, check the tub rim for level and both walls for plumb. If either are out of plumb more than 3/8", you may want to contact your dealer for tapered fillers which can be used to level tub track or plum the side jambs.



**Caution: Tempered glass cannot be cut or drilled**

# 1.

## SETTING POSTS

### Step 1a.

- Mark centerline of shower sill then determine which side will have fixed glass panel.
- Take 180-degree post (X) and hold on centerline mark. Plumb jamb and mark holes.

**Note:** Attachments to fiberglass or acrylic can be made in two ways: if reinforcement is built into the wall of the unit, drill 3 1/8" diameter holes and install the screws directly into the reinforcement.

If wall is not reinforced, drill 3/16" holes and install plastic wall anchors (C).

1a

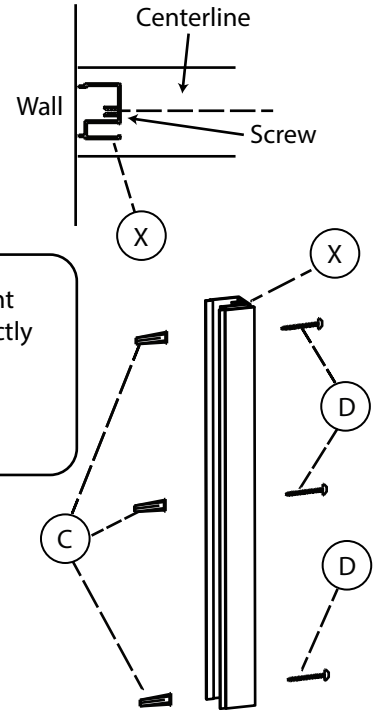

### Step 1b.

- Secure 180-degree post (X) with three #8 X 1 1/2" pan head screws (D).

1b

# 2.

## MEASURING for TUB TRACK

### Step 2a.

- Take sill (M) and push into 180-degree post (X) about 1/2". Make sure open part of sill is up.
- Press 180-degree post (X) and attached wall jamb (B) over sill (M) and push in 1/2".
- Measure from wall to joint of 180-degree post (X) and wall jamb (B) and cut tub track (A) 1/8" less than measurement.
- Pull off 180-degree (X) and wall jamb (B).

2a

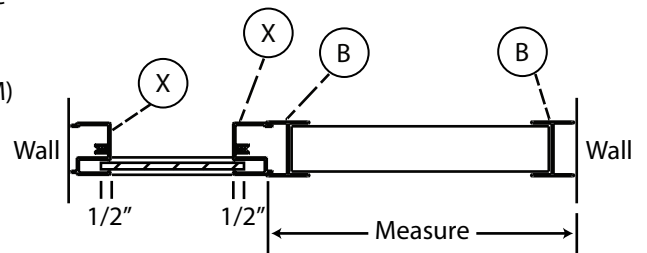

# 3.

## SECURING the TUB TRACK

### Step 3a.

- Place tub track on centerline of sill. Secure with tape.
- Take wall jamb (B) and use a level to plumb the wall jamb, then mark the pre-drill hole location on the wall.
- Lightly mark along both sides of the track (A) with a pencil, then remove all parts. For tile or marble, drill six (2 per wall) 3/16" diameter holes and insert plastic wall anchors (C). A center punch helps location the holes accurately.

3a

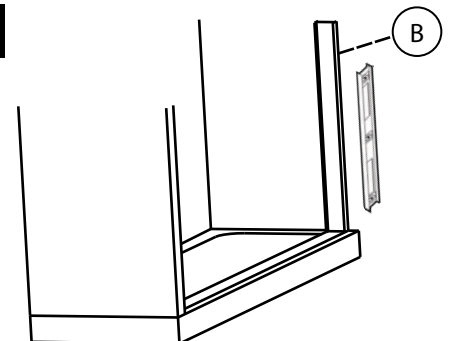

### 3.

#### SECURING the TUB TRACK CONTINUED

##### Step 3b.

- It may be necessary to file a radius on the ends of the tub track and wall jambs to match the corners of the tub.
- Before replacing the tub track (A), force a slight downward bow in the extrusion. This will ensure that the track fits tight to the tub.
- Run two beads of silicone inside the penciled mark on the tub rim. Place the tub track in the exact position you marked in step 3a and set it firmly in the silicone.
- Replace wall jamb (B) and attach to wall with #8 X 1 1/2" screws (D). Do not over tighten jamb screws.

3b

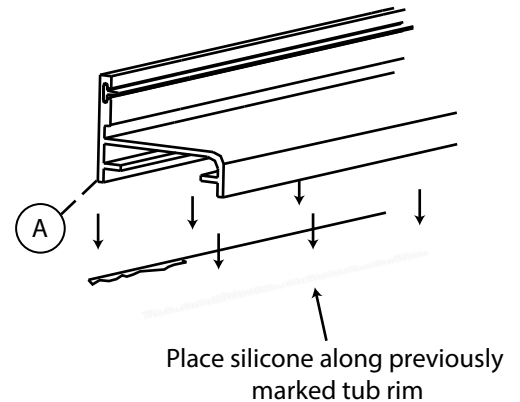

### 4.

#### INSERTING STATIONARY PANEL

##### Step 4a.

- Place glass block (Y) in middle of sill (M) and position glass panel (G) so that both 180-degree posts overlap glass by 1/2".
- Press 180-degree post (X) and wall jamb (B) over tub track with vinyl (A) and on to glass panel.

4a

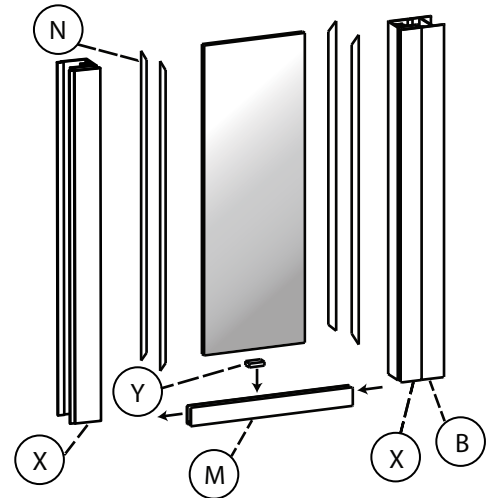

### 5.

#### FITTING the TUB HEADER

##### Step 5a.

- Measure from wall-to-wall at the top of the wall jambs, then mark and cut the tub header (E or F). Set the tub header in place over the top of the wall jamb and 180-degree post.
- From the inside of the enclosure, drill one hole, with a #32 drill bit, through the header and wall jamb on each end of the header and into middle of 180-degree post.
- Attach the header to the tub jamb using three #6 X 1/2" screws (Q).
- Cut the vinyl (N) slightly longer than the opening height to prevent shrinkage.
- Press wall channel vinyl (N) into place, using a wood block. Tap the vinyl into place starting at both ends and working toward the middle. You can spray glass cleaner on vinyl to make it slide in easier. Please refer to diagram 4a.

5a

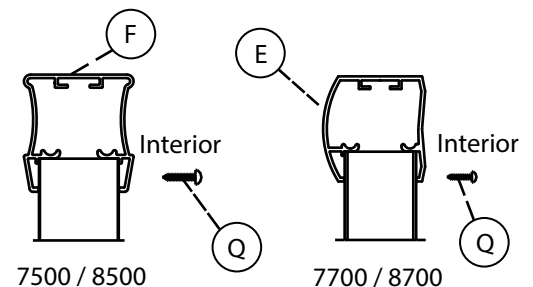

## 6.

### INSTALL the GLASS PANELS

#### Step 6a.

- To install panels, attach the four nylon roller bearings (K) to the door panels using four #6-32 X 3/8" hex head screws (J) centered in the slots in the top fins.

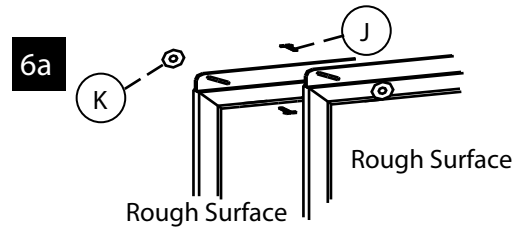

#### Step 6b.

- To set slider glass in place, hold interior panel inside of tub, insert rollers up into header and lower into roller track.

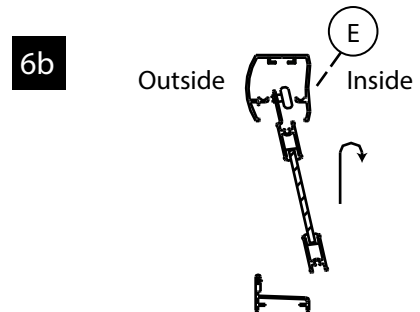

#### Step 6c.

- Next, insert lower end of exterior slider panel in front of interior slider panel by pushing lower ends far enough in to allow clearance on inside edge of tub. Avoid roller-to-roller contact while lifting panel into place. The inside slider panel will close against wall jamb on showerhead side.

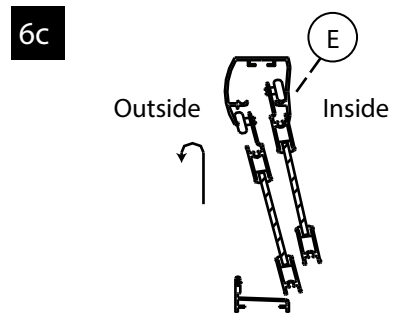

#### Step 6d.

- Next, push vinyl jamb bumpers (H) into side jambs (B) approximately 1" below center screw.
- Align the slot in the bumper with the outer rail of the slider panel and mark holes through the bumper and drill with #32 drill bit.
- Screw bumper in with #6 X 3/4" pan head screw (I).

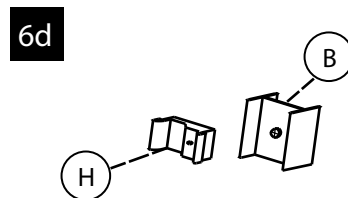

#### Step 6e.

- Repeat for other side. Do not over tighten. If the door panels are not parallel to their respective wall jambs, remove and adjust rollers up or down in their slots to compensate for out of plumb walls.

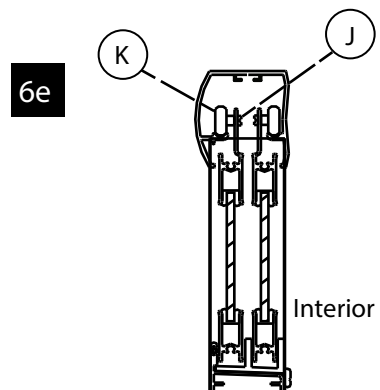

## 7.

### CENTER GUIDE

#### Step 7a.

- Locate the nylon bottom guide (O) in the center of tub track (A) and place the center guide into place.
- Drill through hole with #32 drill bit, using the factory holes as a template, into track.
- Attach center guide with #6 X 1/2" pan head (Q).

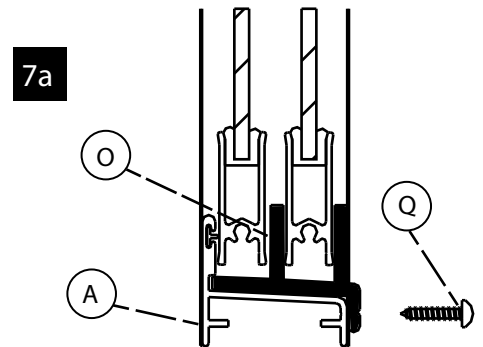

## 8.

### TOWEL BAR

#### Step 8a.

- Slide the four towel bar trim rings (T) over the acrylic towel bar brackets (U) and press the brackets into the ends of the two towel bars (P).

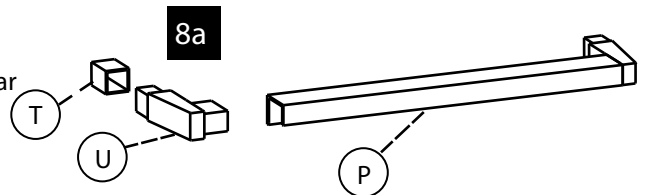

#### Step 8b.

- Attach a towel bar (with the hollow side of the bar down) to the interior panel with a #10 X 7/8" truss head screw (R) through inner rail.
- Insert a #10 X 1 1/8" flat head screw (S) through an acrylic finger pull (V), through the outer rail, and into the outer towel bar bracket.
- Peel the backing from a Splendor cover label (W), press it into the recess in the acrylic finger pull.
- Repeat for the exterior door panel. **Do not** over tighten the towel bar screws.
- This is for a setup of shower head on right. Reverse if on the left. Inside panel should be closest to the shower head.

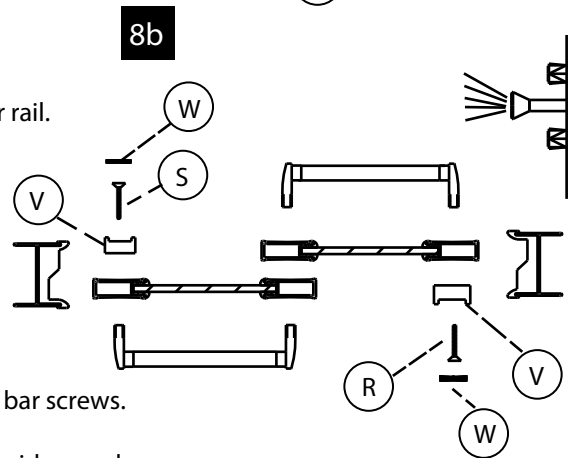

## 9.

### TOWEL BAR

#### Step 9a.

- Silicone each end of tub tracks (A) where they meet the wall jambs (B). Run a bead of silicone along interior and exterior edge of track.

#### Step 9b.

- We recommend that you let the silicone dry for 24 hours before using the enclosure.

