

## VERTICAL CROSS SECTION

NOTE: Tub slider has two round towel bars.

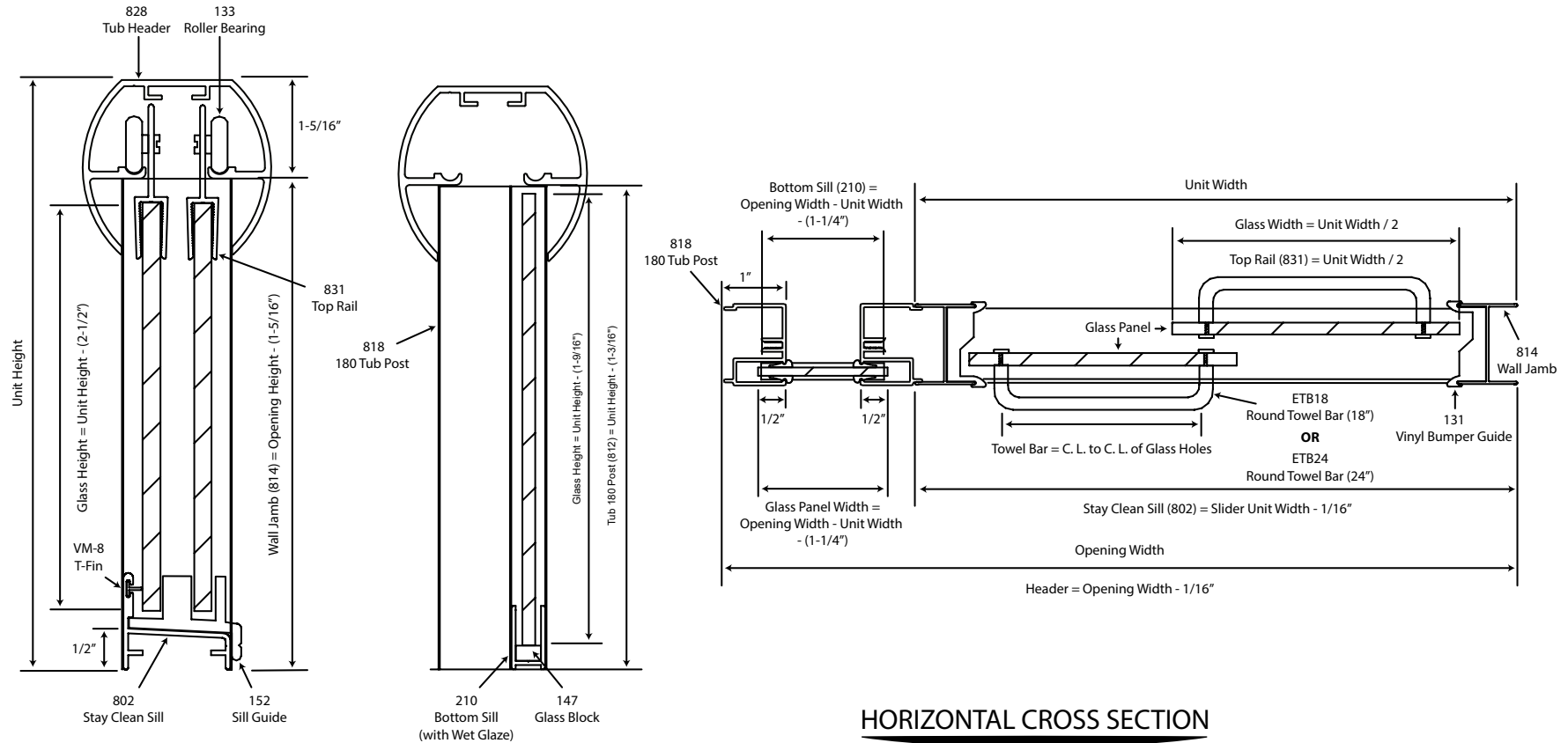

NOTE: Glazing material for all KD units and glazed units must conform to Anzi Z97.1 and CPSC Standard 16 CFC 1201 Category I and II.

**SERIES**

**5920/6920  
Slider & Inline Panel**

**EURO**

For Different Sizes of Unit Heights and Unit Widths  
See Price Book

**Splendor**

QUALITY GLASS PRODUCTS

1133 S. McCord Road  
Holland, Ohio 43628  
Phone: (419) 866.5667