

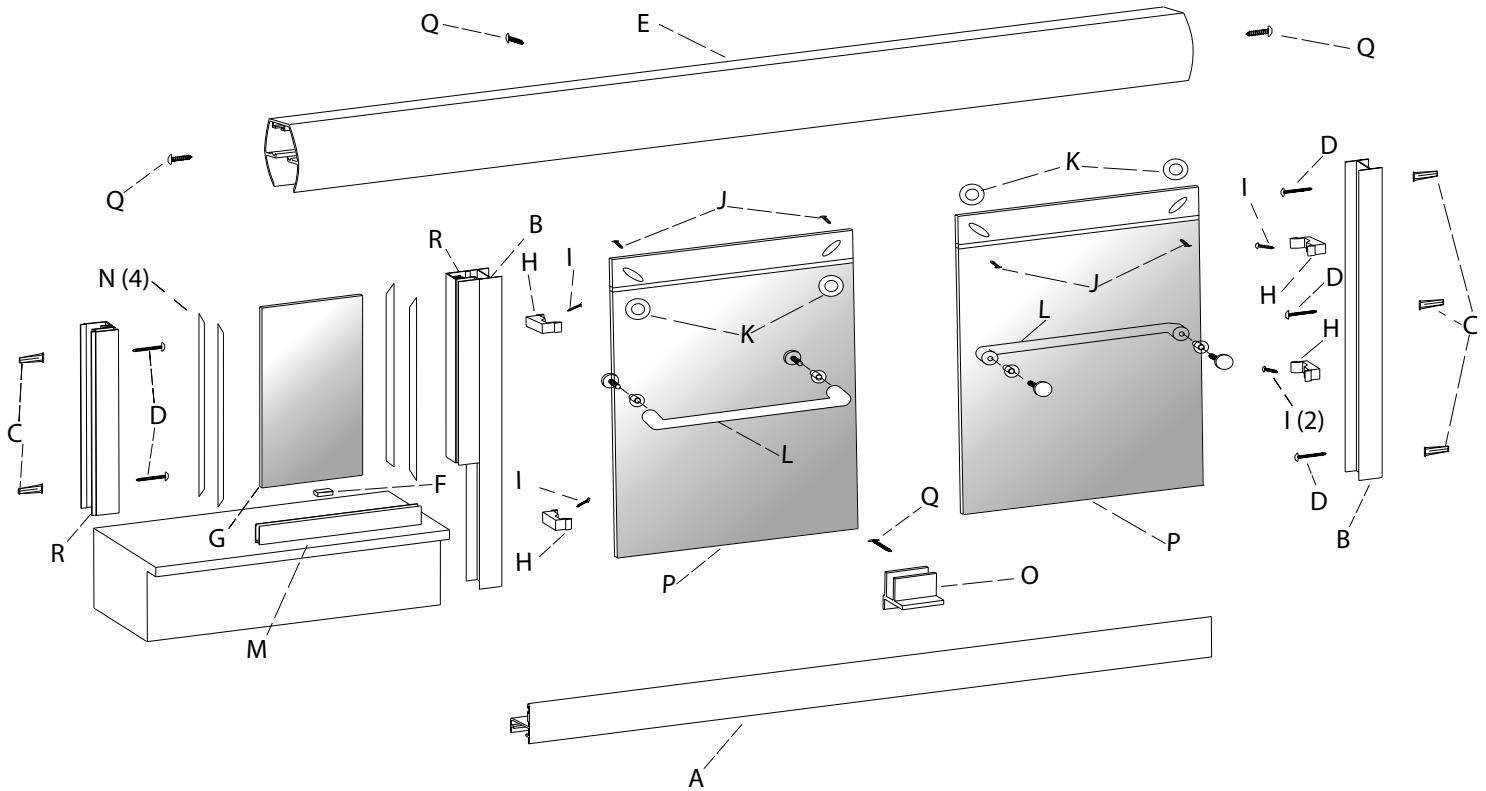

















Installation Instructions

Euro Series 5920 / 6920 with Inline Buttress Panel



Parts

ITEM	PART #	QTY	DESCRIPTION		ITEM	PART #	QTY	DESCRIPTION	
A	802	1	Tub Track with Vinyl		J	116	4	#6 x 32-3/8" Hex Head Screw	
B	814	2	Wall Jamb		K	133	4	Roller Bearing	
C	113	5	Plastic Wall Anchor		L	ETB	2	Towel Bar	
D	110	5	#8 x 1 1/2" Pan Head Screw		M	210	1	Friction Sill	
E	828	1	Tub Header		N	VM-4	4	Wall Channel Vinyl	
F	148	1	Glass Block		O	152	1	Bottom Guide	
G		1	Glass Panel		P		2	Sliding Glass Panel	
H	131	4	Vinyl Jamb Bumpers		Q	119	4	#6 x 1/2" Pan Head Screw	
I	115	4	#6 x 3/4" Pan Head Screw		R	818	2	180-Degree Tub Post	

Tools

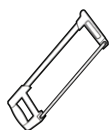

Hacksaw



Philips Screwdriver



Level



#32 and 3/16" Drill Bit



Drill

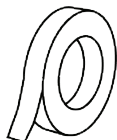

Masking Tape



Safety Glasses



Tape Measure



Silicone



Mallet

Installation Notes

- Unpack your unit carefully. Lay out and identify all parts using the instruction sheets as a reference. Before discarding the carton, check for any small hardware bags.
- If any parts are damaged or missing, refer to the description noted in the instructions when contacting your dealer for replacements.
- Please wear safety glasses whenever drilling or cutting.
- Handle the glazed panels carefully; tempered glass is difficult to break, but the sharp corners of the panels can damage tile and floor coverings.
- Before installing, check the tub rim for level and both walls for plumb. If either are out of plumb more than 3/8", you may want to contact your dealer for tapered fillers which can be used to level tub track or plum the side jambs.



Caution: Tempered glass cannot be cut or drilled

1.

SETTING POSTS

Step 1a.

- Mark centerline of shower sill then determine which side will have fixed glass panel.
- Take 180-degree post (R) and hold on centerline mark. Plumb jamb and mark holes.

1a

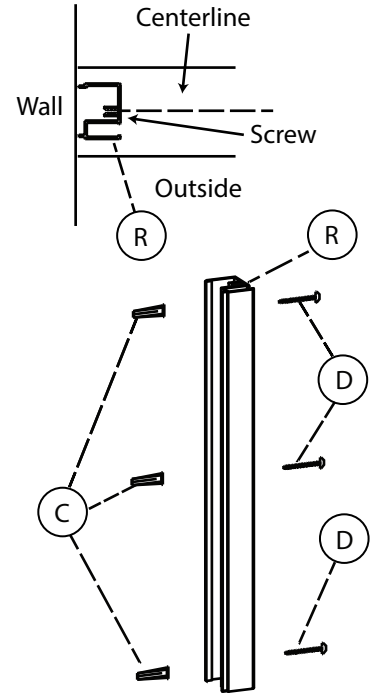

Step 1b.

- Secure 180-degree post (R) with three #8 X 1 1/2" pan head screws (D).

1b

2.

MEASURING for TUB TRACK

Step 2a.

- Take sill (M) and push into 180-degree post (R) about 1/2". Make sure open part of sill is up.
- Press 180-degree post (R) and attached wall jamb (B) over sill (M) and push in 1/2".
- Mark hole(s) on buttress wall through wall jamb (B).
- Measure from wall to buttress wall and cut tub track (A) 1/8" less than measurement.
- Pull off 180-degree (R) and wall jamb (B).

2a

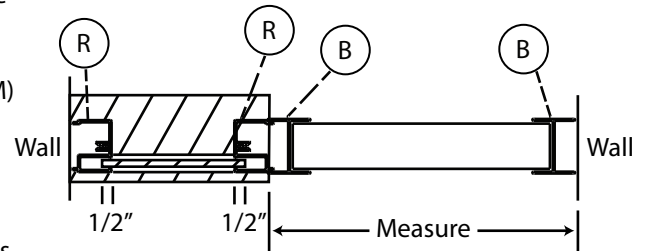

3.

SECURING the TUB TRACK

Step 3a.

- Place tub track (A) on centerline of sill. Secure with tape.
- Take wall jamb (B) and use a level to plumb the wall jamb, then mark the pre-drill hole location on the wall.
- Lightly mark along both sides of the track (A) with a pencil, then remove all parts. For tile or marble, drill three 3/16" diameter holes and insert plastic wall anchors (C). Drill hole on buttress wall the same way. A center punch helps location the holes accurately.

3a

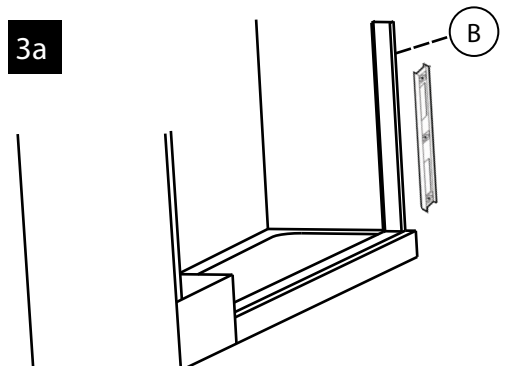

3.

SECURING the TUB TRACK CONTINUED

Step 3b.

- It may be necessary to file a radius on the ends of the tub track and wall jambs to match the corners of the tub.
- Before replacing the tub track (A), force a slight downward bow in the extrusion. This will ensure that the track fits tight to the tub.
- Run two beads of silicone inside the penciled mark on the tub rim. Place the tub track in the exact position you marked in step 3a and set it firmly in the silicone.

3b

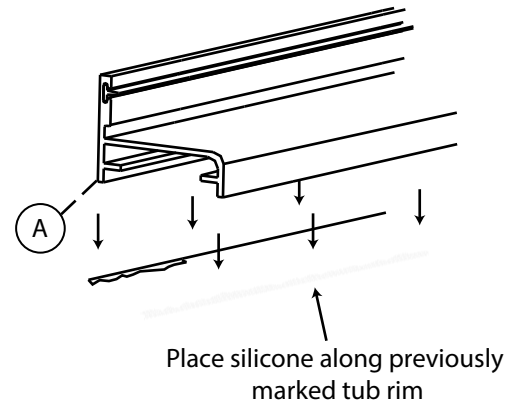

4.

INSERTING STATIONARY PANEL

Step 4a.

- Place glass block (Y) in middle of sill (M) and position glass panel (G) so that both 180-degree posts overlap glass by 1/2".
- Press 180-degree post (X) and wall jamb (B) over tub track with vinyl (A) and on to glass panel.
- Replace wall jamb (B) and attach to wall with #8 X 1 1/2" screws (D). Do not over tighten jamb screws.

4a

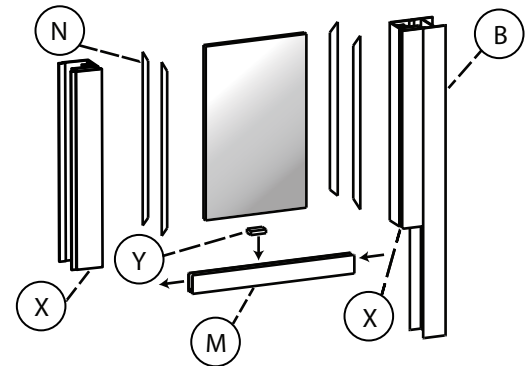

5.

FITTING the TUB HEADER

Step 5a.

- Measure from wall-to-wall at the top of the wall jambs, then mark and cut the tub header (E). Set the tub header in place over the top of the wall jamb and 180-degree post.
- From the inside of the enclosure, drill one hole, with a #32 drill bit, through the header and wall jamb on each end of the header and into middle of 180-degree post.
- Attach the header to the wall jamb using three #6 X 1/2" screws (Q).
- Cut the vinyl (N) slightly longer than the opening height to prevent shrinkage.
- Press wall channel vinyl (N) into place, using a wood block. Tap the vinyl into place starting at both ends and working toward the middle. You can spray glass cleaner on vinyl to make it slide in easier. Please refer to diagram 4a.

5a

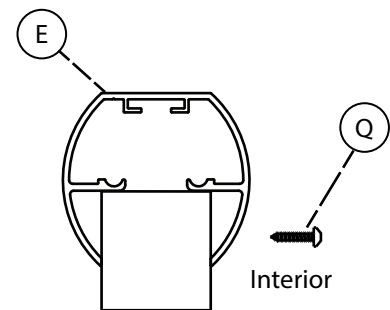

6.

INSTALL the GLASS PANELS

Step 6a.

- To install panels, attach the four nylon roller bearings (K) to the door panels using four #6-32 X 3/8" hex head screws (J) centered in the slots in the top fins. Patterned glass is always installed with the rough surface of the glass to the exterior of the unit.

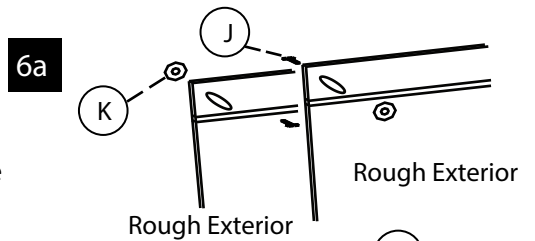

Step 6b.

- To set slider glass in place, hold interior panel inside of tub, insert rollers up into header and lower into roller track.

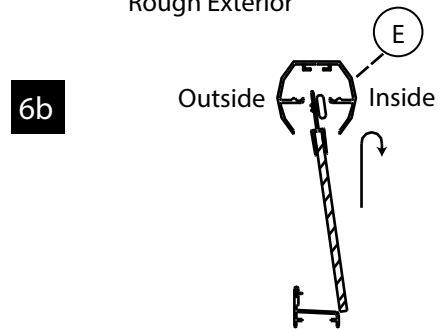

Step 6c.

- Next, insert lower end of exterior slider panel in front of interior slider panel by pushing lower ends far enough in to allow clearance on inside edge of tub. Avoid roller-to-roller contact while lifting panel into place.

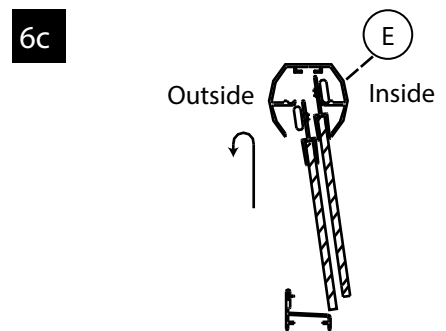

Step 6d.

- The interior panel should **always** be positioned closest to the shower head for maximum waterproofing, as shown in illustration.

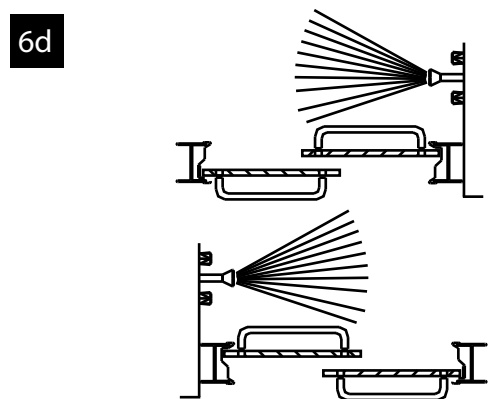

Step 6e.

- Next, push vinyl jamb bumpers (H) into side jambs (B) approximately 1" below center screw.
- Align the slot in the bumper with the outer rail of the slider panel and mark holes through the bumper and drill with #32 drill bit.
- Screw bumper in with #6 X 3/4" pan head screw (I). Repeat on other side. **Do not** over tighten or rubber can tear rubber with movement.

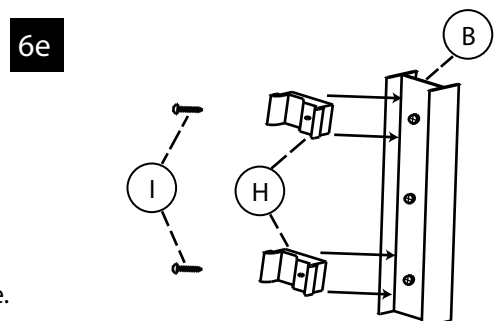

6.

INSTALL the GLASS PANELS CONTINUED

Step 6f.

- If the door panels are not parallel to their respective wall jambs, remove and adjust rollers up or down in their slots to compensate for out-of-plumb walls.

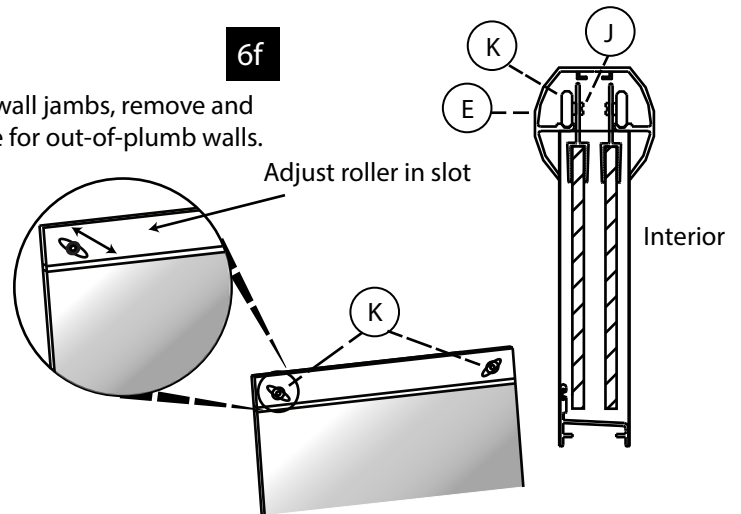

7.

CENTER GUIDE

Step 7a.

- Locate the nylon bottom guide (O) in the center of the stay clean sill (A) and place the center guide into place.
- Using the factory holes as a template, drill through hole into track with #32 drill bit.
- Attach center guide with #6 X 1/2" round head screw (Q).

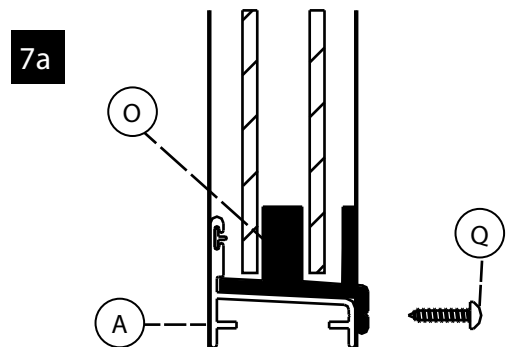

8.

TOWEL BAR

Step 8a.

- Units include two Euro towel bars. These should be enclosed in a sealed box with all components attached. If back of knob hits when rolling enclosure, take clear plastic spacers off. Install on glass using the diagram below as reference.

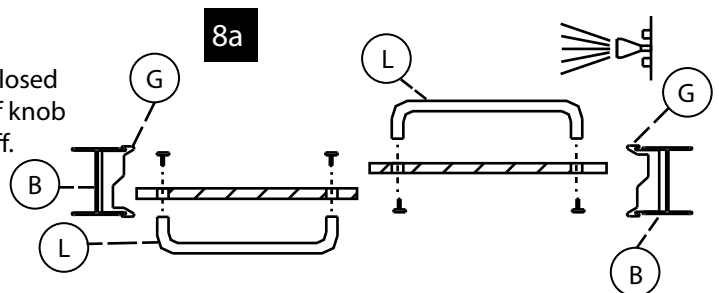

9.

ADDING SILICONE

Step 9a.

- Silicone each end of stay clean sill (A) where they meet the wall jambs (B). Run a bead of silicone along interior and exterior edge of stay clean sill and wall jambs.

Step 9b.

- We recommend that you let the silicone dry for 24 hours before using the enclosure.

