



























Parts

ITEM	PART #	QTY	DESCRIPTION		ITEM	PART #	QTY	DESCRIPTION	
A	802	1	Tub Track with Vinyl		N	148	1	Glass Block	
B	814	2	Wall Jamb		O	836	2	Towel Bar Bases	
C	113	6	Plastic Wall Anchor		P	151	1	Bottom Guide	
D	110	6	#8 x 1 1/2" Pan Head Screw		Q	816	1	Towel Bars	
E	825	2	Tub Header		R	119	5	#6 x 1/2" Pan Head Screw	
F		1	Glass Panel		S	118	2	#10-24 x 1 1/8" Flat Head Screw	
G	131	4	Vinyl Jamb Bumpers		T	158	2	Towel Bar Trim Rings	
H	115	4	#6 x 3/4" Pan Head Screw		U	138	2	Acrylic Towel Bar Bracket	
I	116	4	#6 x 32-3/8" Hex Head Screw		V	837	1	Clamp On Handle	
J	130	4	Roller Bearing		W	820	1	90-Degree Tub Post	
K	VM-4	4	Wall Channel Vinyl		X	818	1	180-Degree Tub Post	
L	145	1	90-Degree Bracket		Y	210	1	Sill	
M	122	4	#6 x 1/4" Phillip Pan MS		Z	VM-18	3	Clamp-On Vinyl (1 1/2")	

Tools



Hacksaw



Philips Screwdriver



Level



#32 and 3/16" Drill Bit



Drill

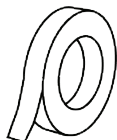

Masking Tape



Straight Edge



Tape Measure



Silicone



Mallet



Safety Glasses

Installation Notes

- Unpack your unit carefully. Lay out and identify all parts using the instruction sheets as a reference. Before discarding the carton, check for any small hardware bags.
- If any parts are damaged or missing, refer to the description noted in the instructions when contacting your dealer for replacements.
- Please wear safety glasses whenever drilling or cutting.
- Handle the glazed panels carefully; tempered glass is difficult to break, but the sharp corners of the panels can damage tile and floor coverings.
- Before installing, check the tub rim for level and both walls for plumb. If either are out of plumb more than 3/8", you may want to contact your dealer for tapered fillers which can be used to level tub track or plum the side jambs.



Caution: Tempered glass cannot be cut or drilled

1.

MARKING for POSTS

Step 1a.

- Measure from wall to the center of 180-degree post (X) and center of wall jamb (B). This is centerline of enclosure. Plumb the 180-degree post (X) and wall jamb (B) on centerline.
- Mark holes and remove the 180-degree post (X). Drill marked holes with a 3/16" drill bit (for tile or marble use a 3/16" masonry bit).

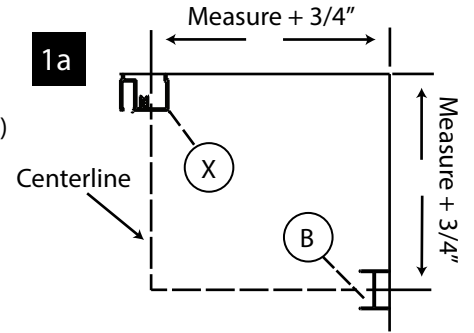

Note: Attachments to fiberglass or acrylic can be made in two ways: if reinforcement is built into the wall of the unit, drill three 1/8" diameter holes and install the screws directly into the reinforcement.

If wall is not reinforced, drill 3/16" holes and install plastic wall anchors (C).

Step 1b.

- Secure 180-degree post with three #8 X 1 1/2" pan head screws (D).

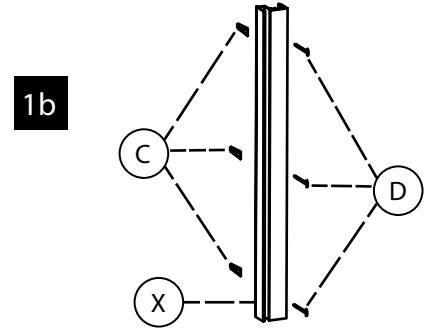

2.

POSITIONING WALL POSTS

Step 2a.

- Insert sill (Y) 1/2" into 180-degree post (X).
- Press 90-degree post (W) and attach wall jamb (B) into sill (Y) 1/2".
- Make sure 90-degree post and wall is on centerline of enclosure.

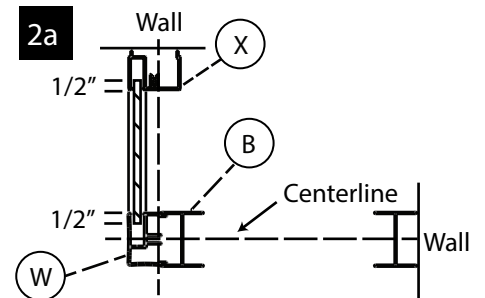

3.

PREPARING the TUB TRACK

Step 3a.

- Measure from wall to outside edge of 90-degree tub post (W).
- Take this measurement and subtract 1 5/8" and cut tub track (A) to that dimension.
- Pull off 90-degree tub post (W) and wall jamb (B). Position the tub track in the center of the tub rim and press it against wall jamb (B) with the tall leg facing the exterior.

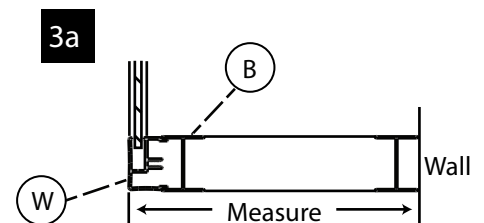

3.

PREPARING the TUB TRACK CONTINUED

Step 3b.

- Press both wall jambs (B) into position over the tub track. Masking tape can be used to temporarily hold parts in place.
- Wall jamb (B) and 90-degree tub post (W) may become fastened from factory.

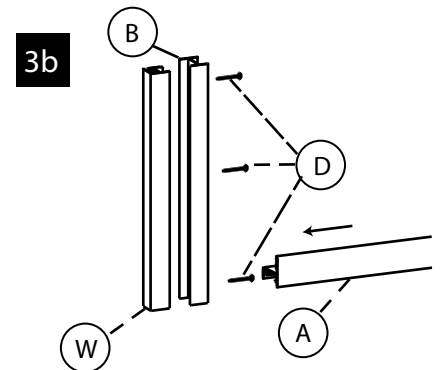

4.

MARKING for WALL JAMB

Step 4a.

- Use a level to plumb both wall jambs (B), then mark the pre-drilled hole locations on the wall. You can use a center punch or pencil.
- Lightly mark along both sides of the tub track (A) with a pencil. Remove all parts and drill the walls using a 3/16" drill bit (for tile or marble use 3/16" masonry bit). Insert wall anchors (C) into holes. A center punch helps locate the holes accurately.

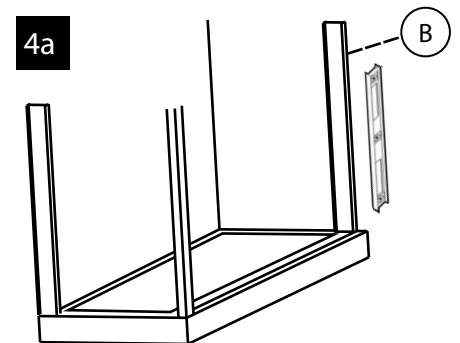

Note: Attachments to fiberglass or acrylic can be made in two ways: if reinforcement is built into the wall of the unit, drill six 1/8" diameter holes and install the screws directly into the reinforcement.

If wall is not reinforced, drill 3/16" holes and install plastic wall anchors (C).

5.

SECURING the TUB TRACK

Step 5a.

- Before replacing the tub track (A), force a slight downward bow in extrusion. This will ensure that the track fits tight to the tub.
- Run two beads of silicone inside the penciled mark on the tub rim. Place the tub track in the exact position you marked in step 4a and set it firmly in the silicone.
- Silicone the end where tub track (A) meets the wall.
- Replace wall jamb (B) and attach to wall with #8 X 1 1/2" screws (D). Do not over tighten jamb screws.

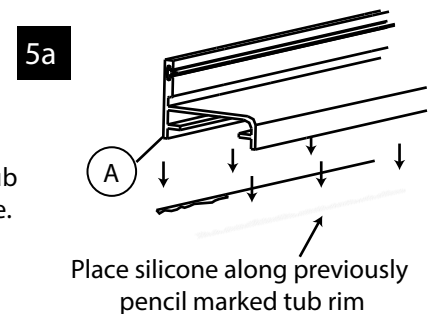

6.

POSITIONING STATIONARY PANEL

Step 6a.

- Insert sill (Y) into 180-degree post (X). Press 90-degree post (W) into sill. Place glass block (N) in the middle of sill (Y).
- Position glass panel (F) so the 180-degree and 90-degree posts overlap glass by 1/2".
- Cut the vinyl slightly longer than the opening to prevent shrinkage.
- Press the interior vinyl into place. Use a wood block to tap the exterior vinyl into place starting at both ends and working towards the middle

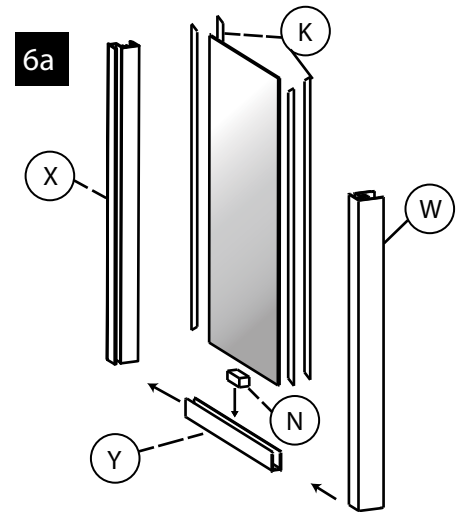

7.

FITTING the TUB HEADER

Step 7a.

- Measure from wall-to-wall at the top of the wall jambs (B), then mark and cut the tub header (E). Set the header in place over the top of the wall jambs (B).

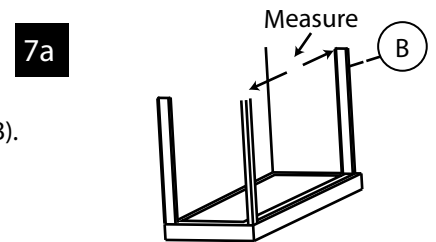

Step 7b.

- From the inside of the enclosure, drill one hole (#32 drill bit) through the header and the wall jamb on each end of the header.
- Attach the header to the tub jamb using two #6 X 1/2" screws (R).

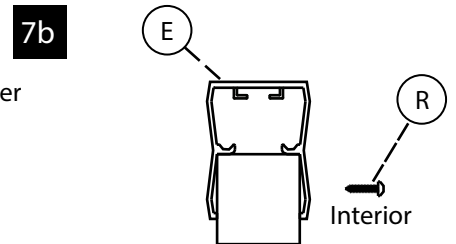

8.

INSTALL the GLASS PANELS

Step 8a.

- To install panels, attach the four nylon roller bearings (J) to the door panels using four #6-32 X 3/8" hex head screws (I) centered in the slots in the top fins. Patterned glass is always installed with the rough surface of the glass to the exterior of the unit.

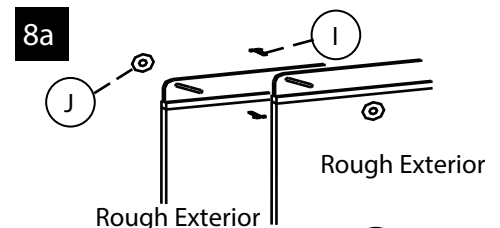

Step 8b.

- To set slider glass in place, hold interior panel inside of tub, insert rollers up into header and lower into roller track.

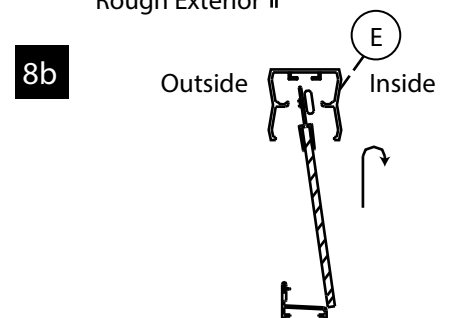

8.

INSTALL the GLASS PANELS CONTINUED

Step 8c.

- Next, insert lower end of exterior slider panel in front of interior slider panel by pushing lower ends far enough in to allow clearance on inside edge of tub. Avoid roller-to-roller contact while lifting panel into place.

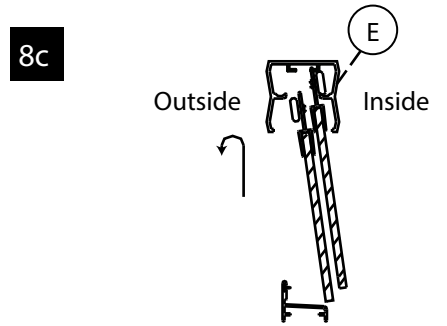

Step 8d.

- The interior panel should **always** be positioned closest to the showerhead for maximum waterproofing, as shown in illustration.

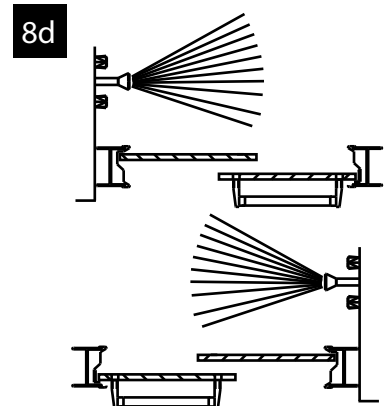

Step 8e.

- Next, push vinyl jamb bumpers (G) into side jambs (B) approximately 1" below top screw and bottom screw.
- Align the slot in the bumper with the outer rail of the slider panel and mark holes through the bumper and drill with #32 drill bit.
- Screw bumper in with #6 X 3/4" pan head screw (H). Repeat on other side.
Do not over tighten or rubber can tear rubber with movement.

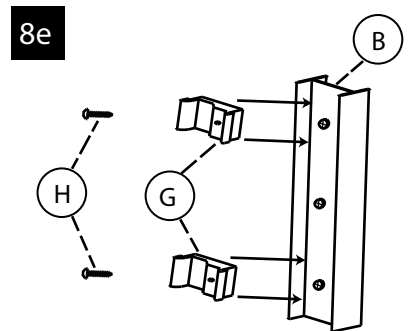

Step 8f.

- If the door panels are not parallel to their respective wall jambs, remove and adjust rollers up or down in their slots to compensate for out of plumb walls.

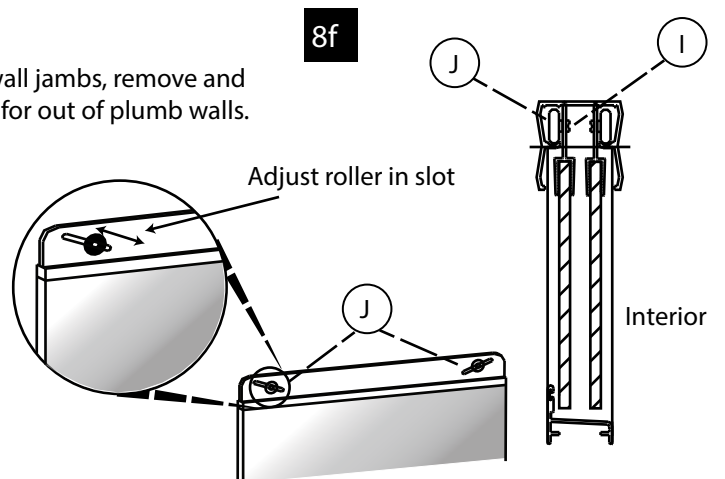

9.

CENTER GUIDE

Step 9a.

- Locate the nylon bottom guide (P) in the center of the tub track (A) and place the bottom guide into place.
- Using the factory holes as a template, drill through hole into track with # 32 drill bit.
- Attach center guide with #6 X 3/8" pan head screw (R).

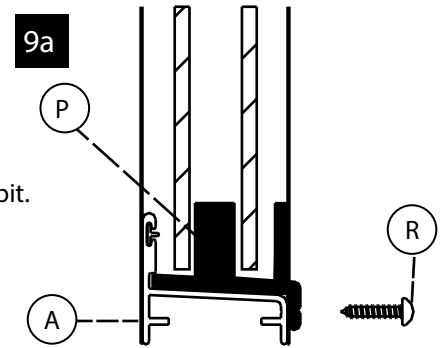

10.

TOWEL BAR and HANDLE

Step 10a.

- Slide the two towel bar trim rings (T) over the acrylic towel bar brackets (U) and attach to the towel bar bases (O) with #10-24 X 1/2" flat head screws (S).
- Force the towel bar (Q) onto one of the brackets. At the center of the exterior glass panel, press the base (with towel bar attached) and vinyl (Z) over the glass.
- Install the remaining base in a similar manner, locking the towel bar into place between the two brackets.

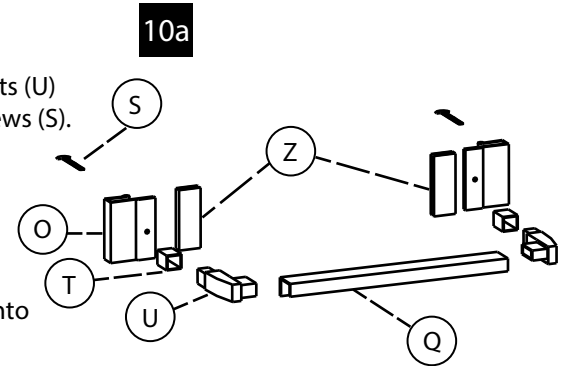

11.

TOWEL BAR and HANDLE

Step 11a.

- Press one clamp on handle (V) and vinyl (Z) into place on the interior glass panel at the same height the towel bar bases (O) were mounted on the exterior panel.
- See illustration in step 10a as reference to which panel the towel bar and handle is applied to.

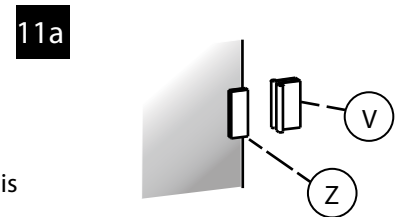

12.

ADDING SILICONE

Step 12a.

- Silicone each end of tub track (A) where they meet the wall jambs (B). Run a bead of silicone along interior and exterior edge of tub track and wall jambs.

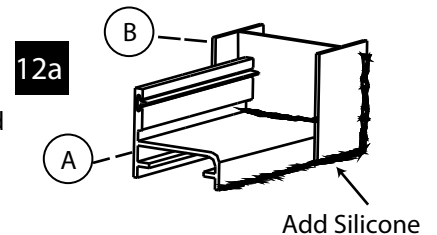

Step 12b.

- We recommend that you let the silicone dry for 24 hours before using the enclosure.



24hrs