















Parts

ITEM	PART#	QTY	DESCRIPTION	
A	420	1	Stall Curb	
B	203	1	Door Wall Channel	
C	435	2	Wall Channel	
D	113	6	Plastic Wall Anchors	
E	110	6	#8 x 1 1/2" Pan Head Screw	
F	147	1	Setting Block	
G		1	3/8" Glass Panel	
H	201	1	Hinge Jamb with Door Attached	
I	VM-46/47	1	Vinyl Latch Jamb with Magnet	
J	262	1	Magnet Holder with Magnets	
K	119	3	#6 x 1/2" Pan Head Screws	
L	402	1	Curb Filler	
M	VM-18	1	Handle Vinyl	
N	VM-12	1	Frameless Dip Bar	
O	EH6X6	1	Handle	

Tools

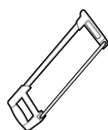

Hacksaw



Philips Screwdriver



Level



3/16" and 1/8" Drill Bit



Drill



Safety Glasses



Tape Measure



Masking Tape

Installation Notes

- The order in which the stationary panel and shower door are placed can be reversed. Door can be hinged left or hinge right. Door must be hinged off of wall.
- Unpack your unit carefully. Lay out and identify all parts using the instruction sheets as a reference. Before discarding the carton, check for any small hardware bags.
- If any parts are damaged or missing, refer to the description noted in the instructions when contacting your dealer for replacements.
- Please wear safety glasses whenever drilling or cutting.
- Handle the glazed panels carefully; tempered glass is difficult to break, but the sharp corners of the panels can damage tile and floor coverings.
- Before installing, check the tub rim for level and both walls for plumb. If either are out of plumb more than 3/8", you may want to contact your dealer for tapered fillers which can be used to level tub track or plum the side jambs.



Caution: Tempered glass cannot be cut or drilled

1.

STALL CURB and WALL CHANNEL

Step 1a.

- Measure the opening and cut the stall curb (A) to fit the full width of the opening.

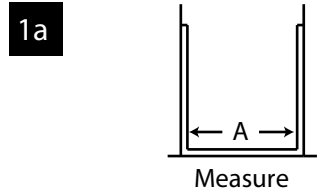

- Position the curb in the center of the opening with the weep slots facing the interior and mark its position.

Step 1b.

- Press the wall channel (B) into the curb (A) on hinge side of the enclosure and wall channel (C) to panel side. Plumb the jambs and mark the hole locations on the wall.
- Remove all parts and drill the wall using 3/16" drill bit. Push the wall anchors (D) into the drilled holes.

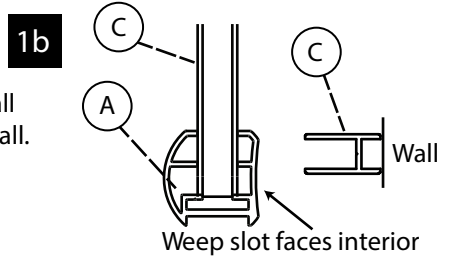

Note: Attachments to fiberglass or acrylic can be made in two ways: if reinforcement is built into the wall of the unit, drill six 1/8" diameter holes and install the screws directly into the reinforcement.

If wall is not reinforced, drill 3/16" holes and install plastic wall anchors (D).

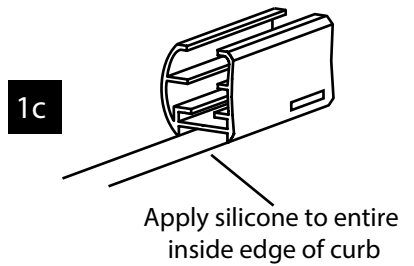

Step 1c.

- Apply silicone to underside of curb (A) and replace the curb back into the previous location. Silicone both ends of curb in the area where it meets the wall.

Step 1d.

- Replace wall channels (B) and (C) then secure to wall with #8 X 1 1/2" pan head screws (E).

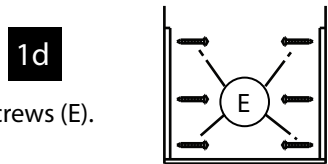

2.

SETTING the GLASS PANEL

Step 2a.

- Insert wall channel (C) into stall curb (A) on panel side of the opening. Push tight against the wall channel (C) on the wall.
- Place setting block (F) in the curb (C) as shown. The setting block should be positioned to support glass panel (G) in the middle of panel.
- Set the glass panel so it rests on the setting block and fits approximately 1/2" into the wall channel (B). If obscure glass is used, the rough surface must be turned to the exterior. Glass panel can be placed on the left or right side of unit.

Note: The 3/8" glass bite on wall channel (C) may be varied from 1/4" to 3/4" to facilitate for out of plumb walls.

- Try to line up the exposed glass edge of panel (G) with the edge of the wall channel (C) inserted into the curb (A).

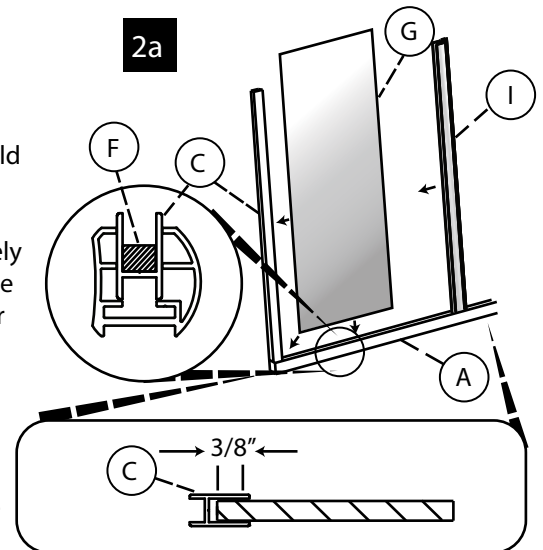

3.

DOOR and PANEL

Note: For the door and panel to fit the opening, the unit has a 3/8" adjustment in the fixed panel and a 1/2" adjustment in the door. Most installers prefer to take the maximum amount of adjustment out of the door.

To determine these adjustments: the glass of the fixed panels must go into the wall channel (C) at least 1/4".

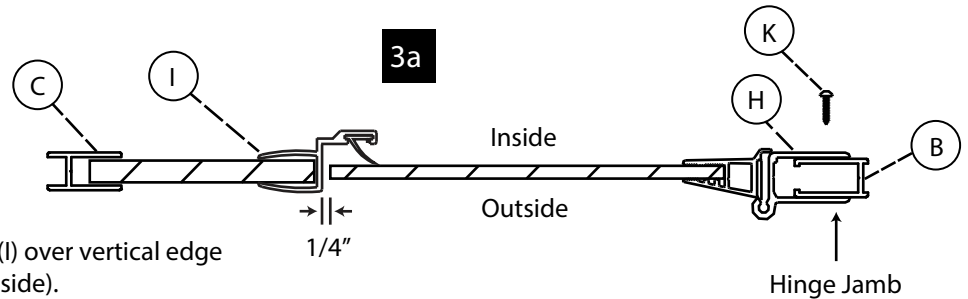

Step 3a.

- Slide on vinyl latch w/ magnet (I) over vertical edge of glass (magnet facing the outside).
- From inside of shower, set the hinge jamb with door attached (H) in place over the door wall channel (B). Close the door so door glass and vinyl latch jamb connects. Adjust door on door wall channel (B) so you have 1/4" gap.
- Next, drill through to the pilot hole of hinge jamb into post using 1/8" drill bit. Secure top hole using a #6 X 1/2" screw (K). The door will hold in place with only top screw.
- Plumb hinge jamb and drill, then secure the other two holes.

4.

MEASURE for CURB FILLERS

Step 4a.

- Measure between the vinyl latch jamb with magnet (I) and the hinge jamb (H). Cut curb filler (L) to this measurement.

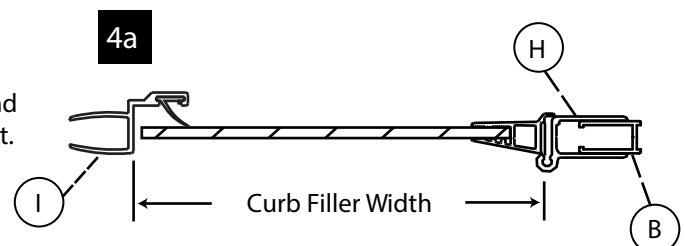

Step 4b.

- Snap curb fillers (L) into stall curb (A) with the 1/8" lip to the outside.

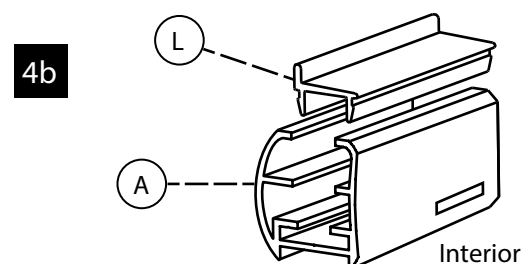

5.

HANDLE ATTACHMENT

Step 5a.

- The vinyl on the latch jamb has a notch; the magnet holder with magnet will be placed on glass and shut on notch.
- Wrap handle vinyl (M) around edge of glass, then push the magnet holder (I) onto the vinyl. This goes on hard to prevent the magnet holder from moving. May have to pound with mallet.
- Make sure the magnet in the magnet holder is on inside of the shower. Shut door to make sure magnets are touching.
- Add handle (O) through holes in glass. Set screws should be on the inside.

5a

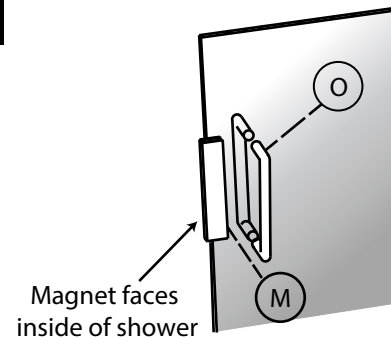

6.

DRIP BAR

Step 6a.

- Take vinyl drip bar (N). Note that there is a notch on both ends. Measure exposed glass at bottom of door. Cut vinyl (N) 1/2" less than exposed glass.
- If door is hinge right, leave right side notch, opposite for a hinge left. Notch part of vinyl slides under rail that is attached to glass. Push up on glass, making sure lip on vinyl faces inside.

6a

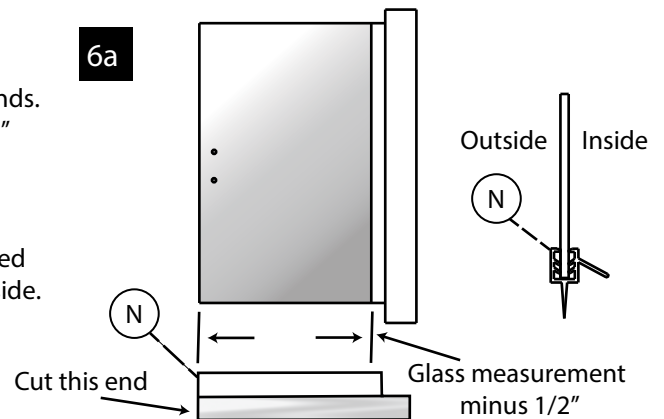

7.

SILICONE SETUP

Step 7a.

- Silicone the entire unit where metal meets wall and curb. We recommend you let silicone set for 24 hours before using shower



24hrs