



















Parts

ITEM	PART #	QTY	DESCRIPTION		ITEM	PART #	QTY	DESCRIPTION	
A	401 C	3	Stall Curb		K	119	14	#6 x 1/2" Pan Head Screw	
B	203	2	Wall Channel		L	201	1	Hinge Jamb with Door Attached	
C	113	6	Plastic Wall Anchors		M	122	16	#6 x 1/4" Phillips Pan Type F	
D	110	6	#8 x 1 1/2" Pan Head Screw		N	VM-4	8	Wall Channel Vinyl	
E	147	2	Setting Block		O	VM-3	8	Stall Header and Curb	
F		2	Glass Panel		P	260	1	Handle	
G	403	2	135 Degree Post		Q	VM-24	1	Handle Vinyl	
H	401 H	3	Stall Header		R	146	4	135-Degree Plates	
I	402	2	Curb Fillers		S	VM-12	1	Vinyl Drip Bar	
J	202	1	Latch Jamb						

Tools

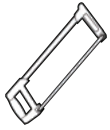

Hacksaw



Philips Screwdriver



Level



3/16" and 1/8" Drill Bit



Drill



Tape Measure



Safety Glasses



Masking Tape

Installation Notes

- Unpack your unit carefully. Lay out and identify all parts using the instruction sheets as a reference. Before discarding the carton, check for any small hardware bags.
- If any parts are damaged or missing, refer to the description noted in the instructions when contacting your dealer for replacements.
- Please wear safety glasses whenever drilling or cutting.
- Handle the glazed panels carefully; tempered glass is difficult to break, but the sharp corners of the panels can damage tile and floor coverings.
- Before installing, check the tub rim for level and both walls for plumb. If either are out of plumb more than 3/8", you may want to contact your dealer for tapered fillers which can be used to level tub track or plum the side jambs.
- All doors are completely reversible and may be installed as hinge left or hinge right. We recommend the hinge should be opposite the showerhead side. It may be installed with hinge on either side, as shown in illustrations. This instruction manual shows a hinge right door hanging off the 135-degree post (S).

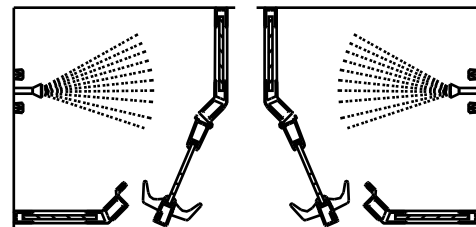

Hinge Right

Hinge Left



Caution: Tempered glass cannot be cut or drilled

1.

STALL CURB and WALL CHANNEL

Step 1a.

- Assemble the three stall curbs (A) by inserting the 135-degree plate (R) into miter ends of curb (the stall curb has the weep slots).

1a

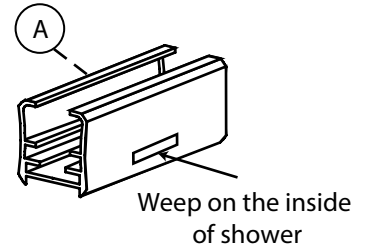

Step 1b.

- Secure the 135-degree plate with the four allen head #6 X 1/4" set screws (M).
- Hold curb tight as you tighten the screws. Do not over tighten screws.

1b

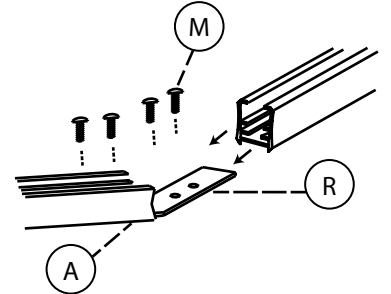

Note: It may be necessary to file a radius on the ends of the stall curb to match to the corners of the fiberglass shower stall.

Step 1c.

- Place curb (A) on the center of the sill with weep slots facing the inside of shower and mark its position.
- Press the wall channels (B) into the curb (A). Plumb the wall channels and mark hole locations on the wall.

1c

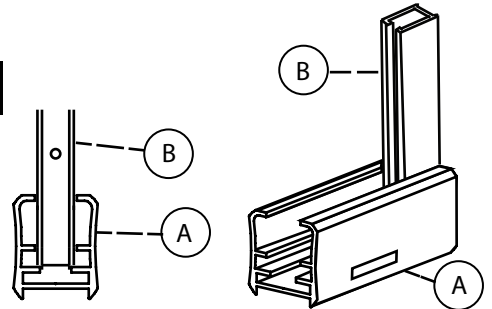

Step 1d.

- Remove all parts and drill the walls with 3/16" drill bit (for tile drill use a 3/16" masonry bit).
- Insert plastic wall anchors (C) into drilled holes. Apply silicone to the underside of curb (A) and replace in the exact position marked.
- Caulk around both ends of the curb in the area where it meets the wall, around the 135-degree brackets, over screw heads, and the interior of the miter joints.
- Replace the wall channels (B) and secure to wall with six #8 X 1 1/2" pan head screws (D).

1d

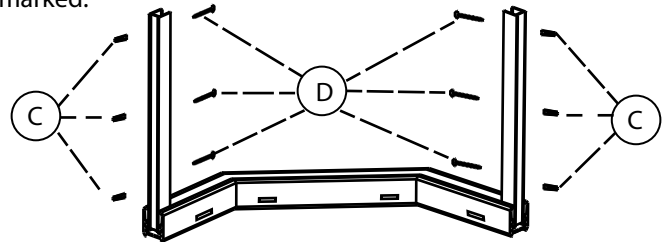

2.

SETTING the GLASS PANELS

Step 2a.

- Place the setting blocks (E) in the curb (A). The setting blocks should be positioned approximately in the center of curb to support the glass panels (F).

2a

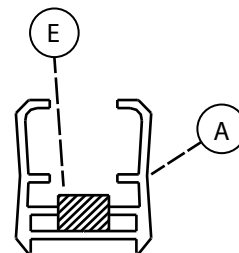

2.

SETTING the GLASS PANELS CONTINUED

Step 2b.

- Install the glass panels. They should rest on the setting blocks and fit in the wall channel approximately 1/2". If patterned glass is used, the rough surface must be turned to the exterior.

2b

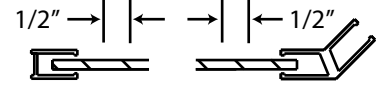

Step 2c.

- Press the 135-degree post (G) into the curb. The post should overlap the glass by 1/2".

2c

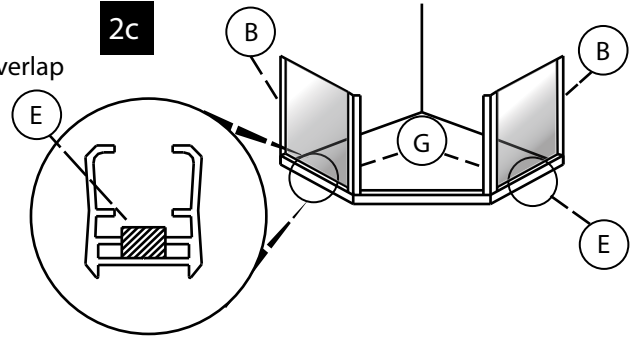

Note: The 1/2" glass bite may be varied from 1/4" to 3/4" to facilitate out-of-plumb walls.

3.

INSERTING the HEADER

Step 3a.

- Assemble the three stall headers (H) by inserting the 135-degree plate into miter ends of the header.
- Secure the 135-degree plate with the four allen head #6 X 1/4" set screws (M).
- Hold curb tight as you tighten the screws. Do not over tighten screws.

3a

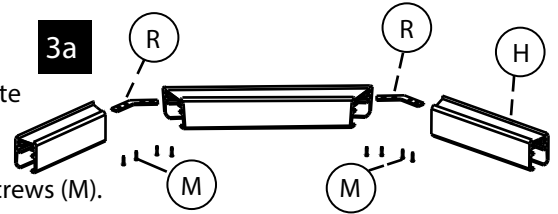

4.

SECURING the HEADER

Step 4a.

- Plumb the 135-degree posts (G). At the top measure from the wall to the top outside corner of the 135-degree post, add 3/16" to this measurement and use this measurement to cut stall header (H) to long point of miter.
- Repeat this on the other side. The center section of the stall header is cut to size at the factory.
- Position stall header (H) (already put together from step 3) over wall channels (B) and the 135-degree post (G).

4a

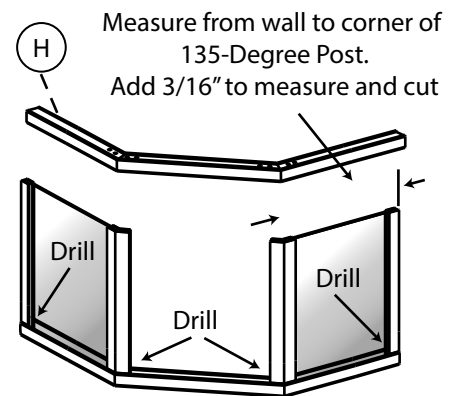

Step 4b.

- Secure stall header (H) and stall curb (A) to wall channels (B) and 135-degree post with #6 X 1/2" pan head screw (K).

4b

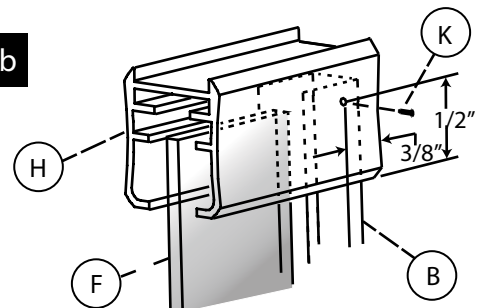

Note: Take notice of the glass location before drilling; the drill bit must not hit glass.

5.

PLACING the DOOR

Step 5a.

- The door is reversible and can swing to the right or left. Decide which way you wish the door to swing.
- Slide latch jamb (J) over the 135-degree post (G) with long side towards the inside.
- Slide hinge jamb with door attached (L) over the other 135-degree post (G).
- Close the door so the magnets are touching. Move the door and make any adjustments if needed on the 135-degree post.
- Check gap above door so that it is even. Using a #32 drill bit, drill the top pilot hole on hinge jamb. Secure with #6 X 1/2" pan head screw (K); door will stay in place with one screw.
- Next, drill and secure remaining five holes.

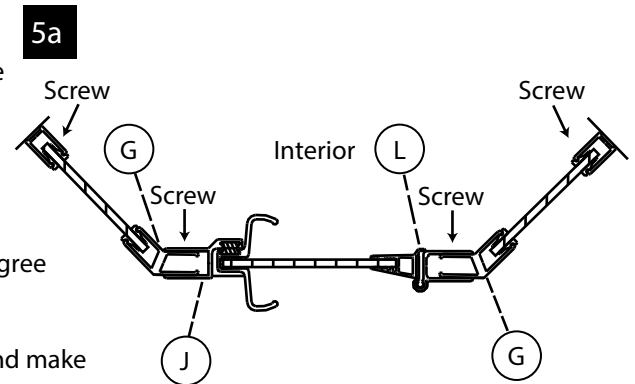

6.

MEASURE for CURB FILLERS

Step 6a.

- Measure between the latch jamb (J) and the hinge jamb (L) and cut curb fillers (I) to this measurement (this measurement is the same as lower rail on door + 5/16").

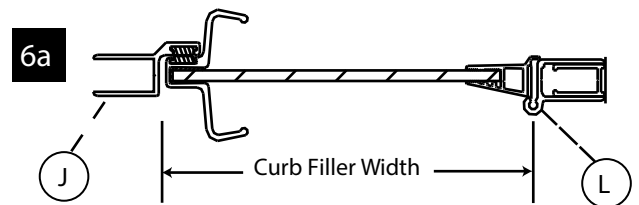

Step 6b.

- Snap curb fillers into stall header (H) and stall curb (A) with 1/8" lip facing out.

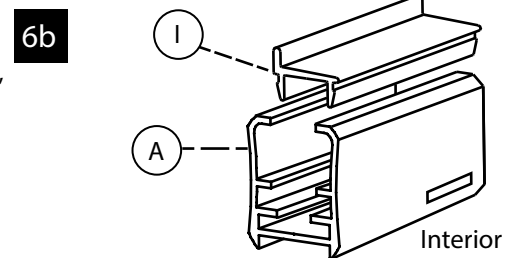

7.

HANDLE ATTACHMENT

Step 7a.

- The magnet on the handle (P) must mate with magnet on the latch jamb (J).
- Wrap handle vinyl (Q) around edge of glass, push the handle over vinyl. This goes on hard so there is no movement in handle.
- Make sure the magnet on the handle is facing the inside of the shower.
- Shut door so magnets close on each other.

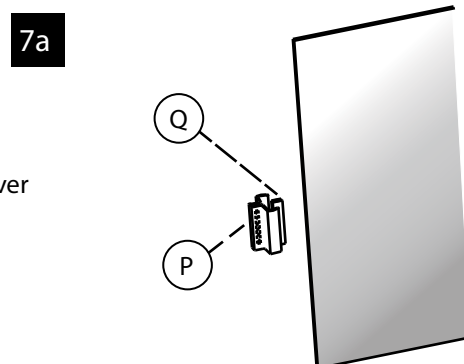

8.

APPLYING the VINYL STRIPS

Step 8a.

- Inspect the glazing vinyl and note that there are two profiles. The larger profile (O) is installed horizontally and the smaller profile (N) is installed vertically. The horizontal vinyl is installed first.
- Cut the vinyl slightly longer than the opening (this prevents shrinkage). Press the interior vinyl into place.
- Use a wood block to tap the exterior vinyl into place starting at both ends and work towards the middle.
- Install the bottom vinyl in the same manner.
- Install the vertical vinyl being sure the corners fit tightly against the horizontal vinyl. If vinyl is difficult to tap on, lubricate the glass and vinyl with glass cleaner, then press on vinyl.

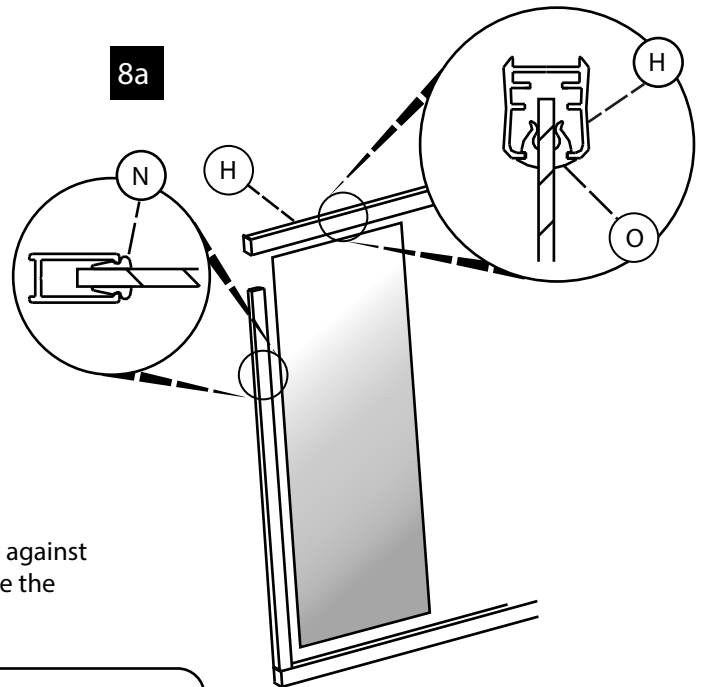

Note: The wall channel vinyl (I) may be provided with four strips in one. Tear each strip off.

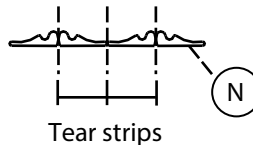

9.

DRIP BAR

Step 9a.

- Take vinyl drip bar (S) and note that there is a notch on both ends. Measure exposed glass at bottom of door. Cut vinyl 1/2" less than exposed glass.
- If door is hinge right, leave right side notch, opposite for a hinge left. Notch the part of the vinyl that slides under rail that is attached to glass. Push up on glass, making sure lip on vinyl faces inside.

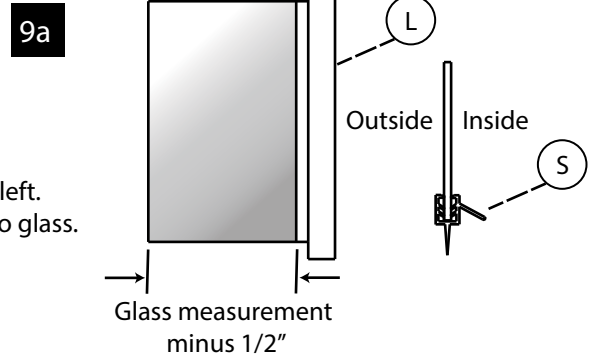

10.

SILICONE SETUP

Step 10a.

- Silicone the entire unit where metal meets wall and curb. We recommend you let silicone set for 24 hours before using shower



24hrs