

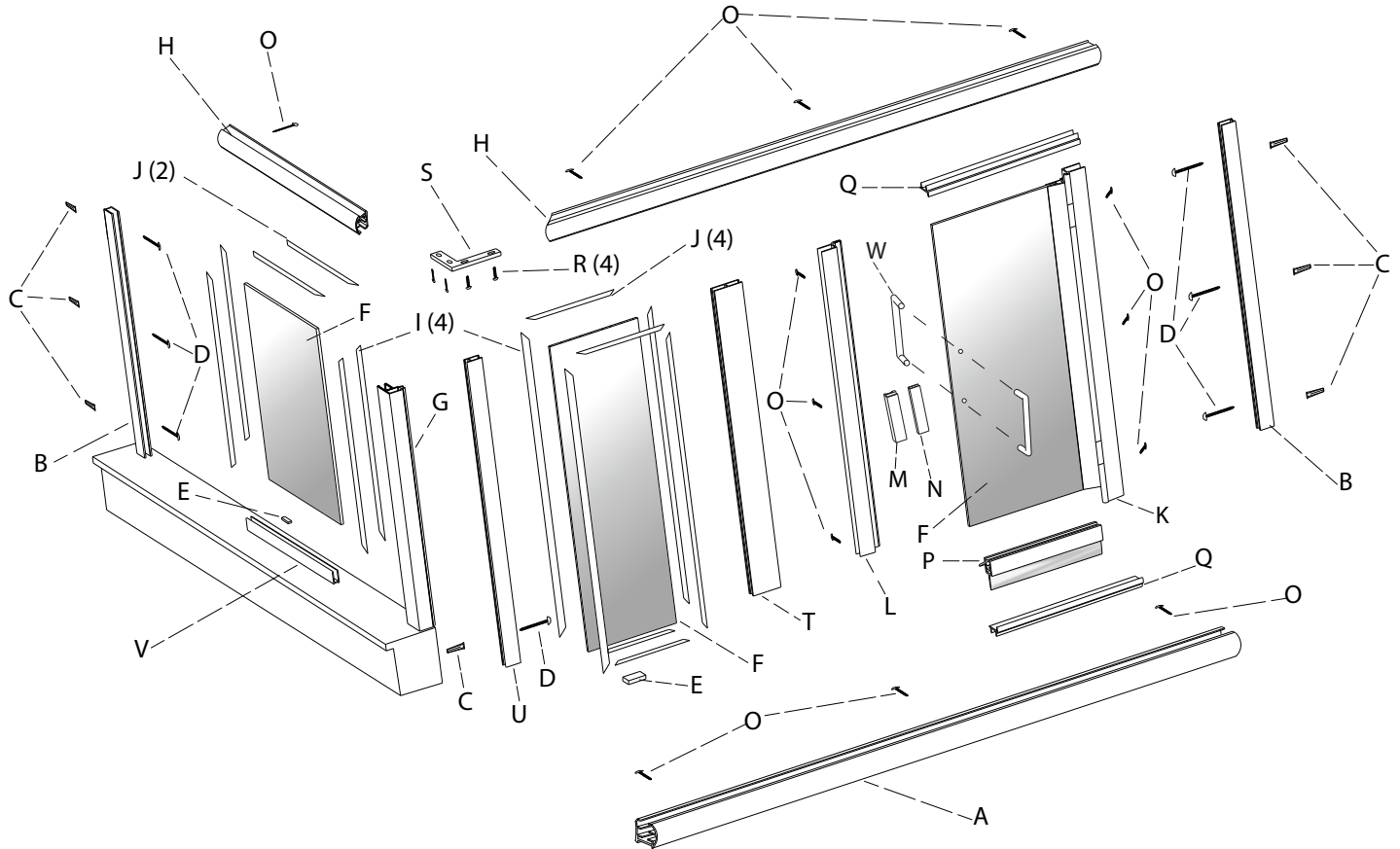























# Installation Instructions

## Euro Series 2700 / 2750 with Buttress Return Panel



### Parts

ITEM	PART #	QTY	DESCRIPTION		ITEM	PART #	QTY	DESCRIPTION	
A	420 C	1	Stall Curb		M	262	1	Magnet Holder with Magnets	
B	203	2	Wall Channel		N	VM-18	1	Handle Vinyl	
C	113	7	Plastic Wall Anchors		O	119	13	#6 x 1/2" Pan Head Screws	
D	110	7	#8 x 1 1/2" Pan Head Screw		P	VM-12	1	Frameless Drip Vinyl	
E	147	2	Setting Block		Q	402	2	Curb Fillers	
F		3	Glass Panel		R	122	4	#6 X 1/4" Phillips Pan Type F	
G	409	1	90-Degree Snap Post		S	145	1	90-Degree Bracket	
H	420 H	2	Stall Header		T	404	1	180-Degree Post	
I	VM-4	8	Wall Channel Vinyl		U	410	1	180-Degree Snap Post	
J	VM-3	6	Stall Header and Curb Vinyl		V	210	1	Friction Sill	
K	201	1	Hinge Jamb with Door Attached		W	EH6X6	1	Handle	
L	202	1	Latch Jamb with Magnet						

## Tools

---

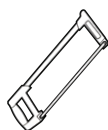

Hacksaw



Philips Screwdriver



Level



3/16" and 1/8" Drill Bit



Drill



Tape Measure



Safety Glasses



Masking Tape

## Installation Notes

---

- Unpack your unit carefully. Lay out and identify all parts using the instruction sheets as a reference. Before discarding the carton, check for any small hardware bags.
- If any parts are damaged or missing, refer to the description noted in the instructions when contacting your dealer for replacements.
- Please wear safety glasses whenever drilling or cutting.
- Handle the glazed panels carefully; tempered glass is difficult to break, but the sharp corners of the panels can damage tile and floor coverings.
- Before installing, check the tub rim for level and both walls for plumb. If either are out of plumb more than 3/8", you may want to contact your dealer for tapered fillers which can be used to level tub track or plum the side jambs.



**Caution: Tempered glass cannot be cut or drilled**

# 1.

## WALL CHANNEL for BUTTRESS

### Step 1a.

- Measure 1/4" from the inside edge of the buttress. Place the edge of the wall channel (B) on the 1/4" mark. Mark hole locations on wall and remove wall channel (B) from buttress.
- Drill the walls with 3/16" drill bit (for tile drill using a 3/16" masonry bit). Insert plastic wall anchors (C) into drilled holes.

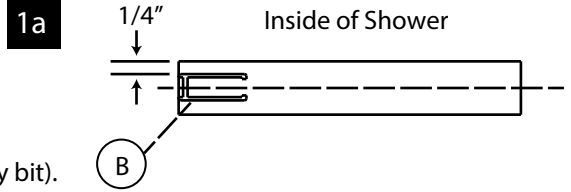

### Step 1b.

- Replace the wall channel (B) and secure to wall with six #8 X 1 1/2" pan head screws (D). Press friction sill (V) into wall channel (B) then press 90-degree snap post (G) with 180-degree snap post (U) attached into friction sill (V).
- Plumb 90-degree snap post (G) with 180-degree snap post (U) attached and mark hole on bottom. Drill the walls with 3/16" drill bit (for tile drill using a 3/16" masonry bit).
- Insert plastic wall anchors (C) into drilled hole.

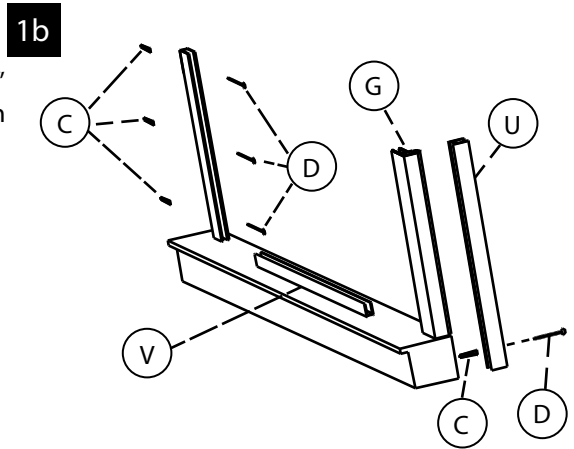

# 2.

## BUTTRESS GLASS

### Step 2a.

- Press friction sill (V) into wall channel (B). Place setting block (E) into friction sill so that the setting block will fit in the middle of glass panel (F). Place glass into friction sill (V) and wall channel (B).

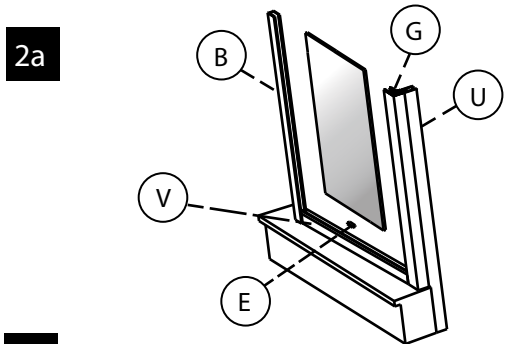

### Step 2b.

- Next, press 90-degree snap post (G) over friction sill (V) and glass so the glass goes 1/2" into the 90-degree snap post.

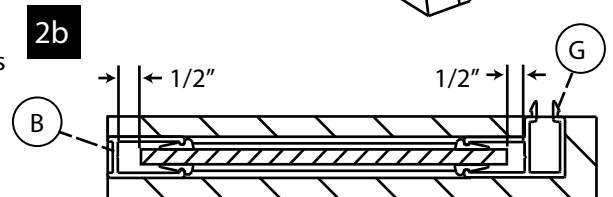

### 3.

#### STALL CURB and WALL CHANNEL

##### Step 3a.

- Measure the opening from the buttress wall to the full wall and cut the stall curb (A) to fit the full width of the opening. Position the curb in the center of the opening with the weep slots facing interior and mark its position.

3a

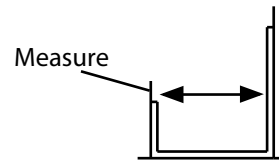

##### Step 3b.

- Press the wall channels (B) into the curb (A). Plumb the wall channels (B) and mark the hole locations on the wall.
- Remove all parts and drill the wall for plastic wall anchors using 3/16" drill bit. Push the wall anchors (C) into the drilled holes.

3b

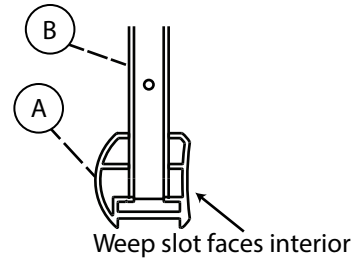

##### Step 3c.

- Apply silicone to underside of curb (A) and replace curb in previous location. Silicone both ends of curb in area where it meets the wall.

3c

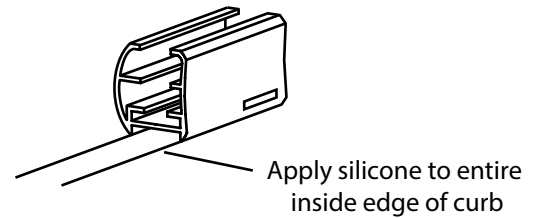

##### Step 3d.

- Replace wall channels (B) and secure to wall with three #8 X 1 1/2" pan head screws (D).
- Replace 90-degree snap post (G) with 180-degree snap post (U) into stall curb (A). Secure with one #8 X 1 1/2" pan head screw.

3d

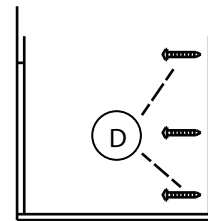

### 4.

#### SETTING the GLASS PANEL

##### Step 4a.

- Place setting block (E) in the curb (A) as shown. The setting block should be positioned to support glass panel (F) in the middle of panel.
- Set the glass panel so it rests on the setting block and fits approximately 1/2" into the 180-degree snap post (U). If obscure glass is used, the rough surface must be turned to the exterior.
- Press the 180-degree post (T) into the curb (A) and position to overlap glass panel (F) by 1/2".

4a

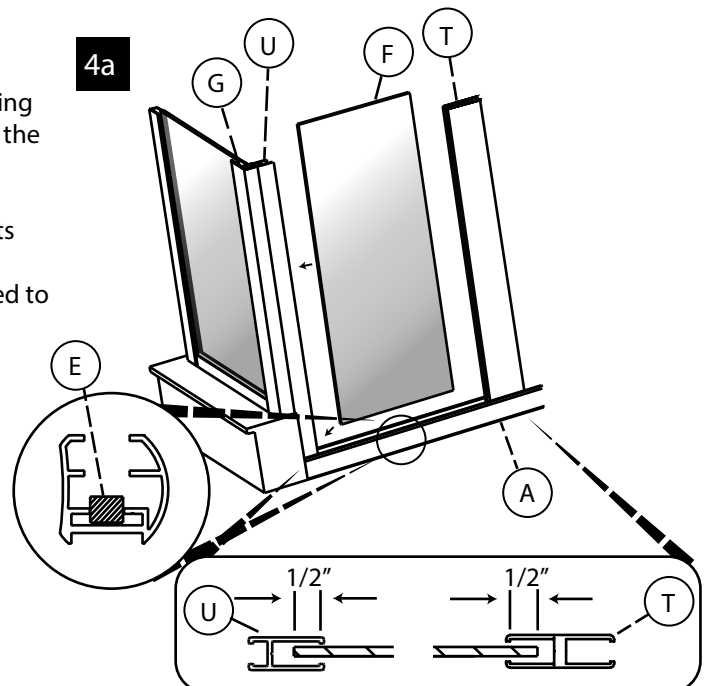

**Note:** The 1/2" glass bite may be varied from 1/4" to 3/4" to facilitate out of plumb walls.

# 5.

## SECURING the HEADER

### Step 5a.

- Measure the wall-to-wall opening at the top of the wall channels (B) to the 90-degree snap post (G), add 1/4" and cut the header (H) to fit exact opening; do this for both ends.

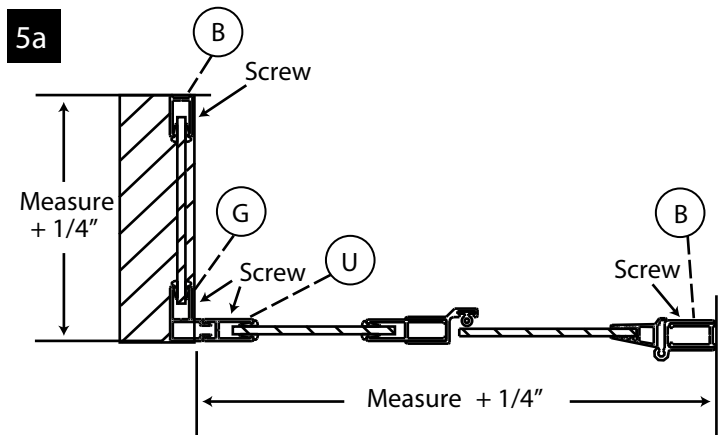

### Step 5b.

- Using the holes in the 90-degree bracket (S) as a guide, mark and drill matching holes in the headers (H) with #32 drill bit and secure the 90-degree bracket (S) with four #6 X 1/4" screws (R).

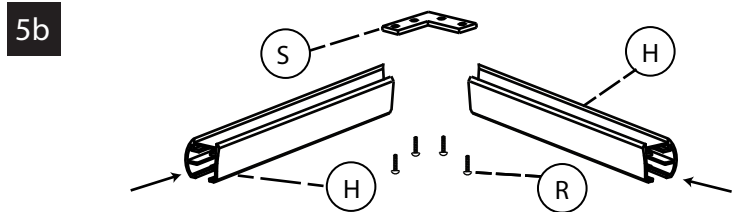

### Step 5c.

- Place header (H) over vertical posts; secure header to wall channels by drilling holes through header and wall channels from inside of shower with a 1/8" drill bit.
- Slide glass panel (F) away from the wall channels before drilling. The drill bit must not hit the glass.
- Secure with #6 X 1/2" pan head screws (O). Repeat for other side and bottom two corners.
- Reposition the glass panel.

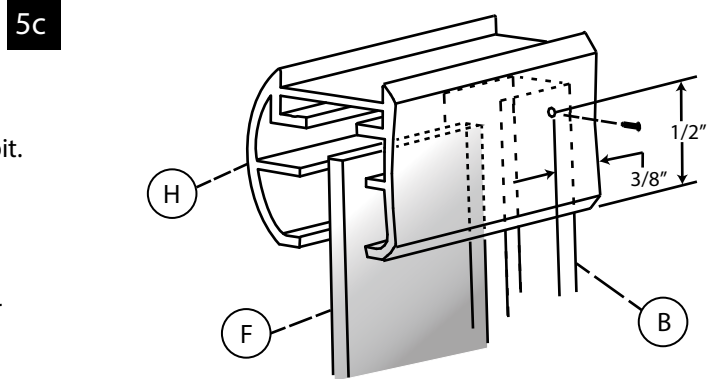

**Note:** Headers (H) come 3" longer to compensate for out of plumb walls. Make sure when cutting to size, you cut the sides of the headers that will be butting up to the wall, **NOT** mitered corners that meet and are secured by the 90-degree bracket (S).

## 6.

### MEASURING for DOOR

#### Step 6a.

- For the door and panel to fit the opening, the unit has a 1" adjustment in the fixed panel and a 1" adjustment in the door, 1/2" maximum adjustment at each end. Most installers prefer to take the maximum amount of adjustment out of the fixed panel.
- The glass of the fixed panels must go into the 180-degree snap post (U) and 180-degree post (T) at least 1/4" on both sides; this is to ensure that the vinyl will hold the glass properly and provide adequate water protection.
- Secondly, the opening for the door must be large enough. Measure the door panel width (see below). The top and bottom door rails must be equal. Measure the distance between the wall channel (B) and the 180-degree post (T). This measurement between posts must be a 1/2" greater than the door panel width, and no more than 1 1/2" longer than the door panel width.

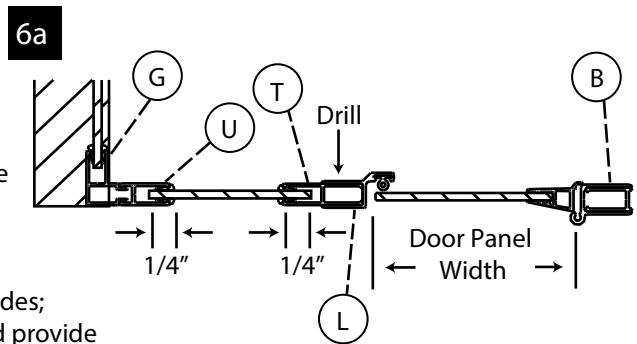

**Note:** A good way to remember this measurement is that the distance between the wall channel and the 180-degree post on the fixed panel side (i.e. daylight) can never be narrower than panel size minus 1 1/2" and never wider than panel size minus 1/2".

**For example:** a 10" panel equals 8 1/2" minimum distance and 9 1/2" maximum distance.

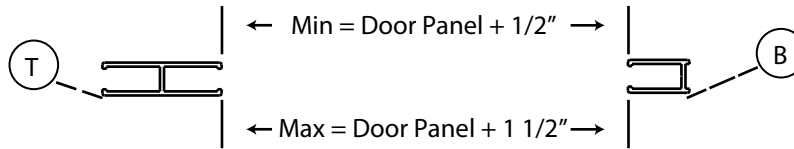

- Next, secure stall header (H) and stall curb (A) to 180-degree post (T) by drilling 1/8" holes and attach with #6 x 1/2" pan head screws (O) (drill away from glass).

## 7.

### PLACING the DOOR

#### Step 7a.

- Determine the direction your door will swing. Set the latch jamb (L) over 180-degree post (T) with the magnet facing the outside, but do not secure.
- From inside the shower, set the hinge jamb with door attached (K) in place over post (T or B depending on configuration).
- Close the door so door magnet and latch jamb magnet connects. Adjust door on wall channel (B) and 180-degree post (T).

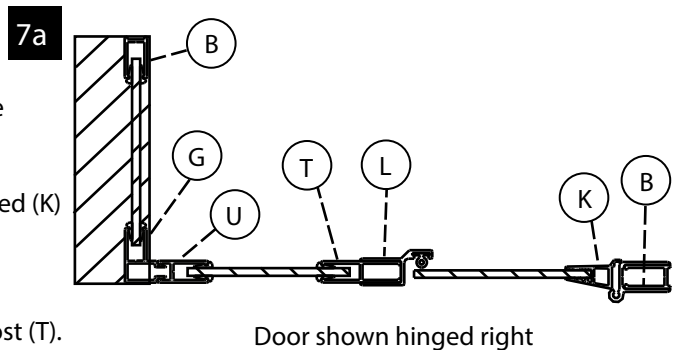

## 7.

### PLACING the DOOR CONTINUED

#### Step 7b.

- Next, drill through top pilot hole of hinge jamb (K) into post using 1/8" drill bit. Secure top hole using #6 X 1/2" screw (O) the door will stay in place with only top screw.
- Plumb hinge jamb and latch jamb then drill and secure the other five holes.

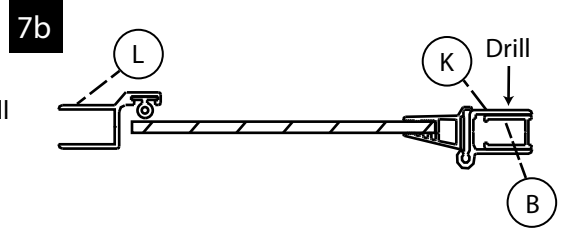

## 8.

### MEASURE for CURB FILLERS

#### Step 8a.

- Measure between the latch jamb (L) and the hinge jamb (K). This should be the same as top or bottom rail of door + 5/16". Cut curb fillers to this measurement.

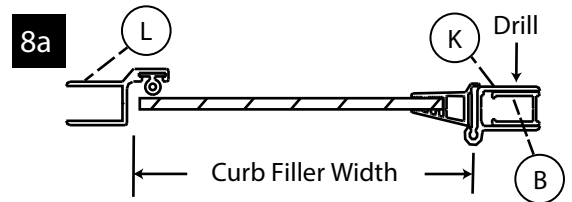

#### Step 8b.

- Snap curb fillers (Q) into stall header (H) and stall curb (A) with the 1/8" lip facing the outside.

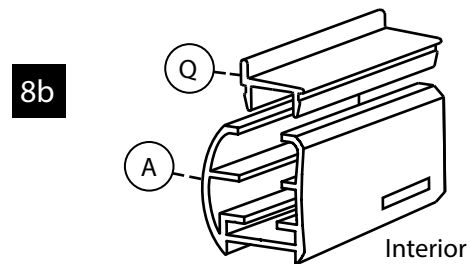

## 9.

### HANDLE ATTACHMENT

#### Step 9a.

- The vinyl on the latch jamb has a notch; the magnet holder with magnet will be placed on glass and shut on notch.
- Wrap handle vinyl (N) around edge of glass, push magnet hold on vinyl. This goes on hard so there is no movement. May have to pound with mallet.
- Make sure the magnet catch on the magnet holder (M) is on inside of the shower. Shut door to make sure magnets are touching.
- Add handle (W) through holes in glass. Set screws should be on the inside.

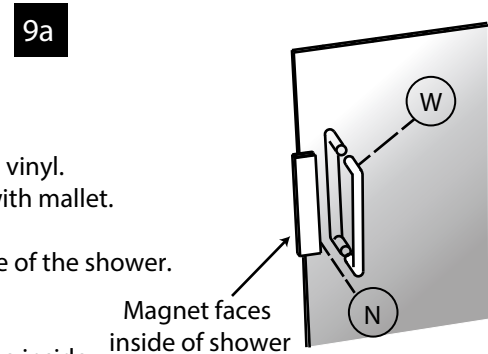

# 10.

## APPLYING the VINYL STRIPS

### Step 10a.

- Inspect the glazing vinyl and note that there are two profiles. The larger profile (J) is installed horizontally and the smaller profile (I) is installed vertically. The horizontal vinyl is installed first.
- Cut the vinyl slightly longer than the opening (this prevents shrinkage). Press the interior vinyl into place.
- Use a wood block to tap the exterior vinyl into place starting at both ends and work towards the middle.
- Install the bottom vinyl in the same manner.
- Install the vertical vinyl being sure the corners fit tightly against the horizontal vinyl. If vinyl is difficult to tap on, lubricate the glass and vinyl with glass cleaner, then press on vinyl.

10a

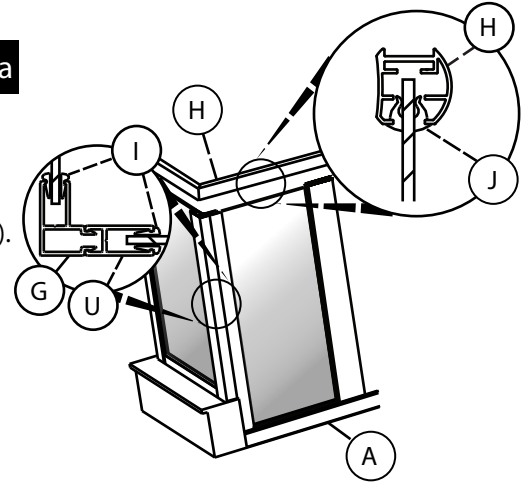

**Note:** The wall channel vinyl (I) may be provided with four strips in one. Tear each strip off.

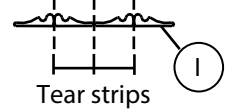

# 11.

## DRIP BAR

### Step 11a.

- Take vinyl drip bar (P) and note that there is a notch on both ends. Measure exposed glass at bottom of door. Cut vinyl 1/2" less than exposed glass.
- If door is hinge right, leave right side notch, opposite for a hinge left. Notch part of vinyl slides under rail that is attached to glass. Push up on glass, making sure lip on vinyl faces inside.

11a

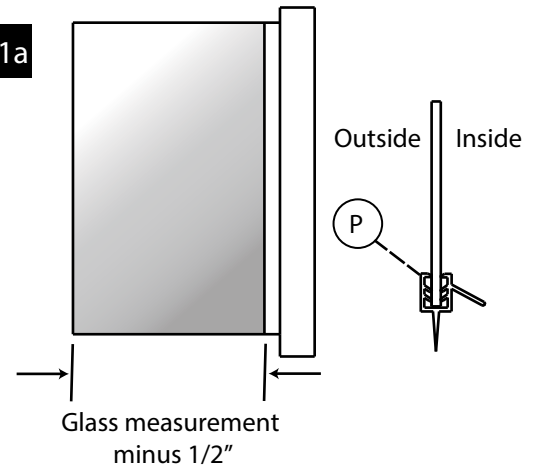

# 12.

## SILICONE SETUP

### Step 12a.

- Silicone the entire unit where metal meets wall and curb. We recommend you let silicone set for 24 hours before using shower

12a



24hrs