

VERTICAL CROSS SECTION

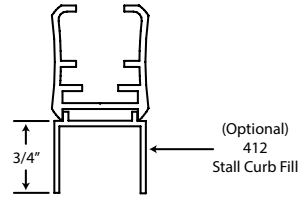

NOTES:

1. Glass bite and overlap of vertical members may be altered to facilitate the use of standard glass sizes or for out of plumb wall conditions.
2. KD door components machined for a maximum glass size of 29 3/4" wide by 63 1/2" and 66 1/2" high. Other sizes may be substituted.

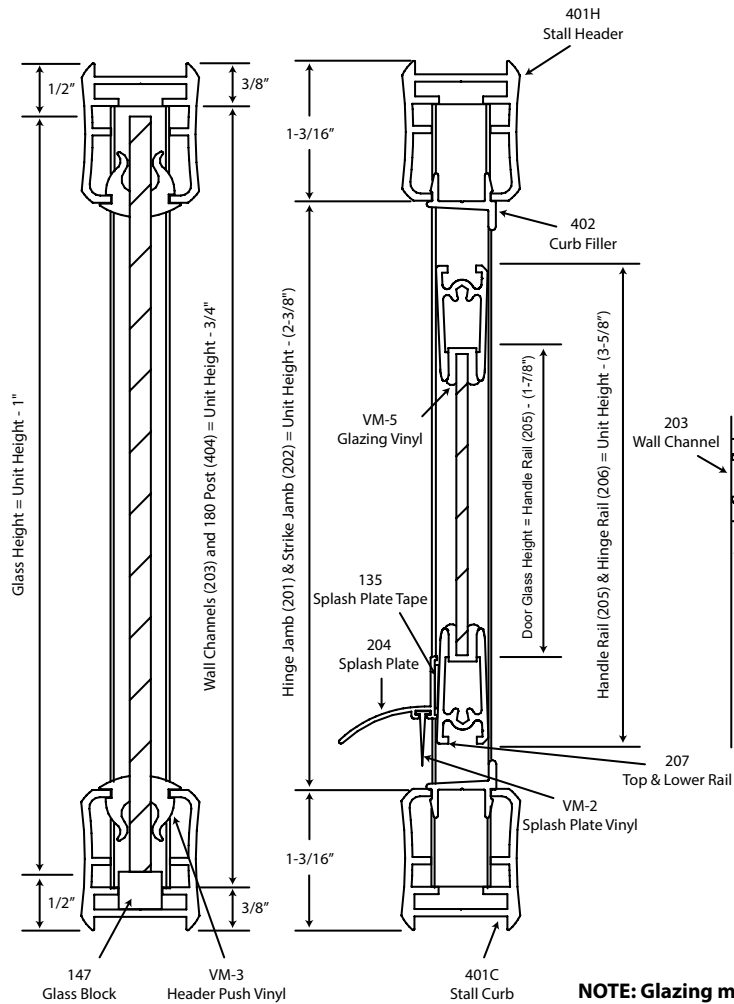
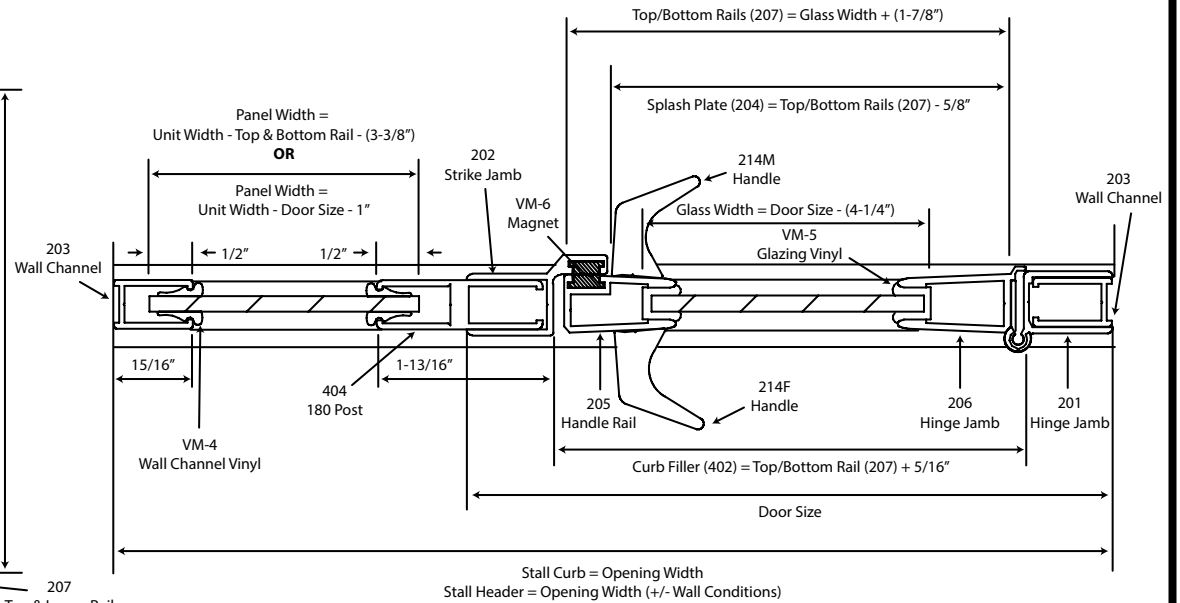

HORIZONTAL CROSS SECTION

NOTE: Glazing material for all KD units and glazed units must conform to Anzi Z97.1 and CPSC Standard 16 CFC 1201 Category I and II.

SERIES

**1200/1225
Door & Panel**

PREMIER

For Different Sizes of Unit Heights and Unit Widths
See Price Book

Splendor

QUALITY GLASS PRODUCTS

1133 S. McCord Road
Holland, Ohio 43628
Phone: (419) 866.5667